



User Manual

DUSH Series | Uninterruptible DC Power Supplies



emea.lambda.tdk.com/dush-series

Table of content

1	Safety regulations / installation notes	1	6.4.1	DUSH System Alarms	30
1.1	General safety instructions	1	6.4.2	DUSH System Events.....	32
1.2	Intended use	1	6.5	INFO	33
1.3	Qualification of users	1	6.6	LOGS.....	34
1.4	System configuration	2	6.7	Configuration Wizard	39
1.5	Firmware update	2	6.8	ON/OFF function	39
1.6	Battery usage.....	2	7	Communication interfaces.....	40
2	Description	3	7.1	Modbus RTU	40
2.1	Disclaimer	3	7.2	Remote HMI	40
2.2	Introduction to DC-UPS	3	8	Operating and basic functions.....	41
2.3	Product description	3	8.1	System overview	41
2.4	Operating and connection elements	4	8.2	Input-Output path.....	42
2.5	Display	5	8.3	Battery-Output path	42
2.6	Alarm LED.....	5	8.4	Auxiliary output	43
2.7	Navigation keys.....	5	8.5	Typical wiring diagram.....	44
2.8	Main approvals.....	6	9	Energy storage technologies	45
3	Mounting / Dismounting.....	7	9.1	Buffer technologies	45
3.1	Mounting	7	9.1.1	Lead acid / Lead gel	45
3.2	Dismounting	8	9.1.2	Nickel metal hydride	45
3.3	Mounting positions	9	9.1.3	Lithium-Ion / Lithium iron phosphate etc.....	45
3.4	Installation clearance / Cooling.....	10	9.1.4	Supercapacitors.....	46
4	Connection / terminal blocks / interfaces.....	11	9.2	Series and parallel connection of batteries.....	46
4.1	Terminal blocks 1.x (IN/OUT/BATT)	11	9.3	Deep discharge	47
4.2	Terminal blocks 2.x (MB-RTU/AUX/R1/R2/INH) .	12	9.4	Recommended battery models.....	47
4.3	Connector 3.0, Temp. Sensor	12	9.5	Discharge tables and diagrams	47
4.4	Connector 4.0, USB connection for Power CMC.....	12	9.6	Battery temperature compensation	48
5	Functional description	13	10	Technical data.....	49
5.1	Battery health monitor.....	13			
5.2	Battery charger	14			
5.3	Coulomb counter.....	15			
5.4	PC shutdown and automatic restart.....	16			
5.5	Cold start.....	17			
5.6	Battery Cycling.....	18			
5.7	Current limit.....	20			
5.8	Shutdown and reset on request	21			
6	Operating	22			
6.1	Menu structure	22			
6.2	STATUS.....	23			
6.3	SETTINGS.....	24			
6.4	System alarms	29			

1 Safety regulations / installation notes

1.1 General safety instructions

- Disconnect the input voltage and energy storage before installation, maintenance or service work and secure it against unintentional reconnection.
- Prevent the ingress of foreign objects, such as screws or metal chips.
- Do not operate the device in a damp environment or in an environment where condensation is likely to occur.
- Make sure that operating personnel are protected against accidental contact with energy-carrying parts.
- Only use insulated tools when working on the product.
- The device must be installed in a protective housing or control cabinet to which only qualified personnel have access.
- If third-party products and components are used for power or voltage increase, energy storage, EMC filtering, redundancies or for DC side load protection, they must be recommended or approved by TDK-Lambda.
- The product must not be modified in any way electrically or mechanically. Modifications can result in fatal injuries and damage to property.
- The power supply is maintenance-free. Repairs can only be carried out by the manufacturer. Opening the housing voids the manufacturer's warranty.
- Consider the current carrying capacity of the cabling and/or any current reduction on the device.
- Only use copper cables that are suitable for at least 90 °C/194 °F.
- Connect or disconnect the device only after the input voltage has been disconnected and the input capacitors have discharged (at least 1 minute).
- Consider machinery directive EN 60204-1. If 2.5 mm² flexible wire are used a 90 °C rated wire is necessary to draw full output current.
- Only use DC-type switch or circuit-breaker due to the specific behavior in usage with DC voltages.

1.2 Intended use

- The DUSH DC-UPS uninterruptible power supply enables the backup of critical loads in the event of a power outage.
- This device is designed for stand-alone operation in an enclosure and is intended for commercial use, such as in industrial control, process control, monitoring and measurement equipment or the like. Do not use this device in equipment where malfunction may cause severe personal injury or threaten human life.

1.3 Qualification of users

- Electrically skilled persons or persons instructed by them. The users must be familiar with the relevant safety concepts of automation technology as well as applicable standards and other regulations.
- Qualified application programmers and software engineers. The users must be familiar with the relevant safety concepts of automation technology as well as applicable standards and other regulations.

1.4 System configuration

- In order to guarantee the optimal functionality of the DUSH, it is essential to configure the system parameters through one of the following methods: PowerCMC, Modbus, or directly on the device. Otherwise, the DUSH may enter an error state.

1.5 Firmware update

To guarantee the safe and seamless operation of the DUSH, it is imperative to utilise the most recent version of both the PowerCMC remote HMI software and the DUSH firmware.

- PowerCMC
 - The PowerCMC checks each time the software is started whether an update is available and informs the user of the update available. The latest version of PowerCMC is also available for download on our product website: <https://www.emea.lambda.tdk.com/dush-series>
- Firmware update
 - The firmware update of the DUSH is part of the PowerCMC software
 - After connecting the DUSH to the PowerCMC, the software will check the firmware version of the DUSH and inform the user if a firmware update is available.

1.6 Battery usage

- Please read the safety instructions of the respective battery or supercapacitor manufacturer.
- Front Terminal batteries as well as supercapacitors are supplied in a charged condition and are capable of extremely high short circuit currents. Take care to avoid short circuiting terminals of opposite polarity.
- Keep flames away. In case of accidental overcharge, a flammable gas can leak off the safety vent. Discharge any possible static electricity from clothes by touching an earth connected part or use appropriate earthing equipment (e.g. anti-static earthing wristband).
- Use tools with insulated handles. Do not place or drop metal objects on the battery. Remove rings, wristwatch and articles of clothing with metal parts that may come into contact with the battery terminals.

WARNING

DANGER OF BURNS

Depending on the ambient conditions, the housing temperature can reach very high temperatures.

- Do not touch the housing of the device during operation.
- Once the device has been disconnected from the power supply, do not touch the housing until it has cooled down for a few minutes.

2 Description

2.1 Disclaimer

TDK reserves the right to make changes without further notice to any products herein. TDK makes no warranty, representation or guarantee regarding the suitability of its products for any particular purpose, nor does TDK assume any liability arising out of the application or use of any product, and specifically disclaims any and all liability, including without limitation consequential or incidental damages. "Typical" parameters which may be provided in TDK data sheets and/or specifications can and do vary in different applications and actual performance may vary overtime. All operating parameters, including "Typical", must be validated for each customer application by customer's technical experts. TDK does not convey any license under its patent rights nor the rights of others. TDK products are not designed, intended, or authorized for use as components in systems intended for surgical implant into the body, or other applications intended to support or sustain life, or for any other application in which the failure of the TDK product could create a situation where personal injury or death may occur. Should Buyer purchase or use TDK products for any such unintended or unauthorized application, Buyer shall indemnify and hold TDK and its officers, employees, subsidiaries, affiliates, and distributors harmless against all claims, costs, damages, and expenses, and reasonable attorney fees arising out of, directly or indirectly, any claim of personal injury or death associated with such unintended or unauthorized use, even if such claim alleges that TDK was negligent regarding the design or manufacture of the part.

The Customer should ensure that it has the most up to date version of the document by contacting its local TDK office. This document supersedes any earlier documentation relating to the products referred to herein. The information contained in this document is current at the date of publication. It may subsequently be updated, revised or withdrawn.

The Customer should ensure that TDK product uses the most up to date Software and Firmware provided on TDK website to ensure reliable operation of the system.

All Trademarks recognized. Specifications and information herein are Subject to change without notice.

2.2 Introduction to DC-UPS

This uninterruptible power supply for DIN rail applications offers a high degree of safety in the event of a power loss. Thanks to its comprehensive features, the DUSH can be deployed in a multitude of applications in the fields of industry automation, plant engineering, building control systems, test and measuring technology, and information and communication technology.

2.3 Product description

DUSH960-1248-xM is a high performance digitally controller DC-UPS that can be used in any DC system with a rated voltage between 12 VDC and 48 VDC and up to 20 A power output.

At the core of the device a bidirectional DC/DC buck-boost converter acts as a battery charger when the input supply is present. In case of a power outage (backup) the converter keeps the output voltage regulated draining power from the battery. The converter is digitally controlled.

The device can monitor the internal hardware and the connected battery in order to detect failures and/or malfunctions and alerts the user through both, the log system and own display.

2.4 Operating and connection elements

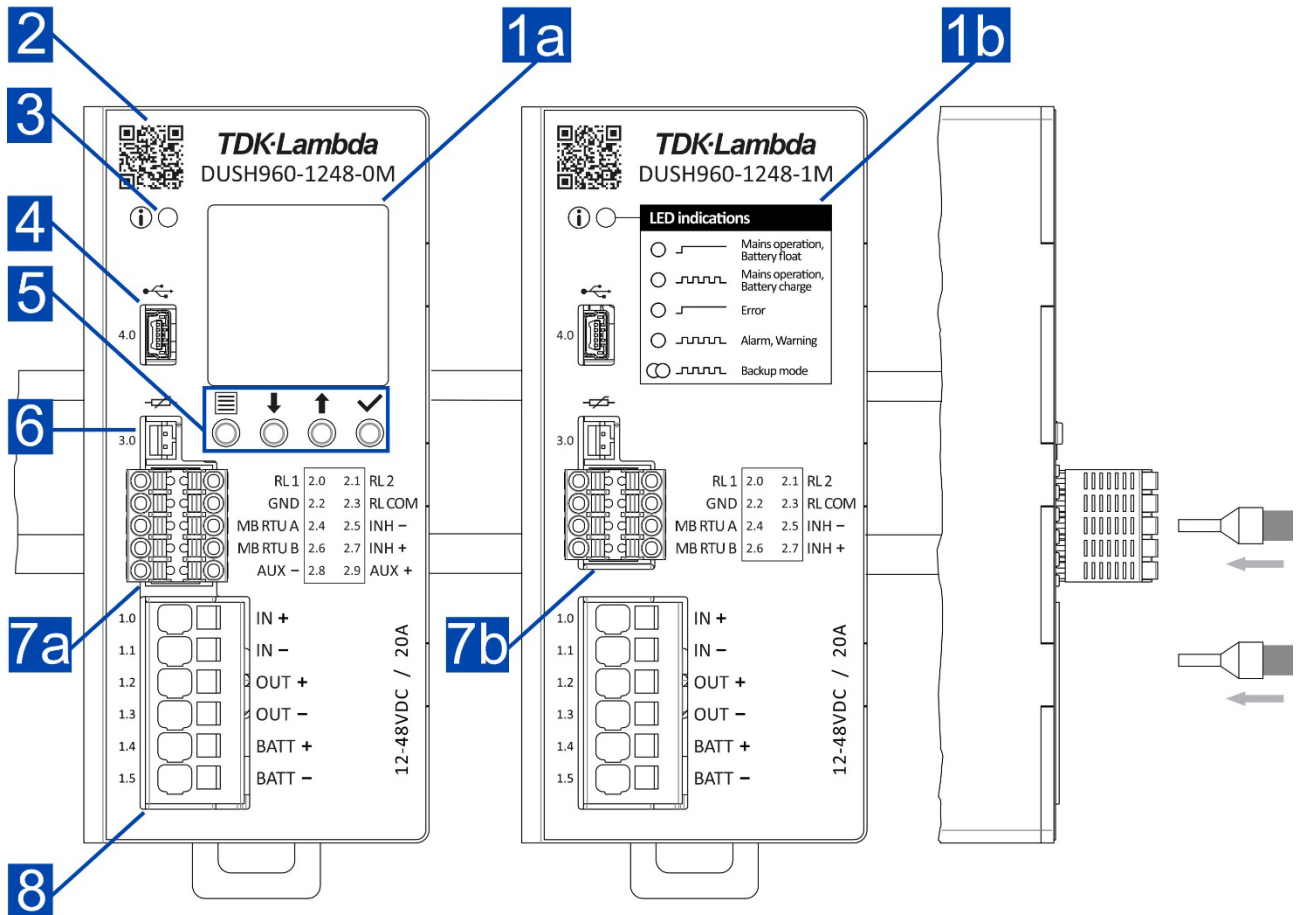

Figure 1 : Operating and connection elements

1a	1,5" color LCD	5	Navigation keys
1b	LED indication info	6	Temperature sensor connector
2	Web link to product documentation	7a	Push-in terminal, pluggable (alarm relays, Modbus/RTU, inhibit, AUX)
3	Alarm LED	7b	Push-in terminal, pluggable (alarm relays, Modbus/RTU, inhibit)
4	Mini USB interface	8	Push-in terminal (input, output, battery)

2.5 Display

The status screen displays the measured values and status information to facilitate system diagnostics. Furthermore, in case of alarm a message appears on the screen after 60 seconds of inactivity (no key pressed).





 IN	U=0.0V I=0.0A
 OUT	U=24.0V I=5.0A
	U=11.2V C=59%
 AUX	U=11.2V I=1.0A

Figure 2 : Menu STATUS







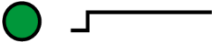

1/1 
Battery disconnected. Check battery and connection.
Bat U=0.0V

Figure 3 : Alarm or warning

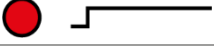



2.6 Alarm LED

LED indication	DUSH960-1248-0M	DUSH960-1248-1M
	–	Mains operation, Battery float
	–	Mains operation, Battery charge
	Backup mode	Error
	Error	Alarm, Warning
	–	Backup mode

2.7 Navigation keys

Symbol	Name	Function
	MENU	Scrolls between menus
	DOWN	Scrolls down menus and values
	UP	Scrolls up menus and values
	ENTER	Confirms selection

2.8 Main approvals

IECEE CB SCHEME	IEC EN 61010-1 IEC EN 61010-2-201 IEC EN 62368-1 (Ed. 2 & Ed. 3)
	UL CSA 61010-1 UL CSA 61010-2-201
	UL CSA 62368-1 (Ed. 3)
	EU Low Voltage Dir. 2014/35/EU EU EMC Dir. 2014/30/EU EU RoHS Dir. 2011/65/EU
	Safety and EMC Reg. 2016 Hazard. Substances Reg. 2012
	China RoHS Law SJ/T 11363-2006

3 Mounting / Dismounting

3.1 Mounting

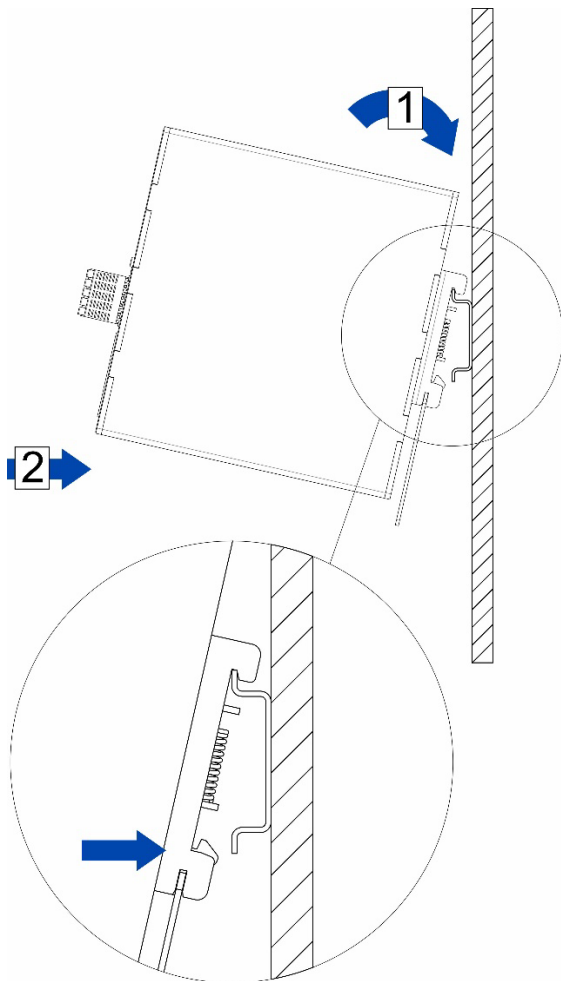

- 1 Place the mounting rail holder on the upper edge of the mounting rail and push down.
- 2 Push the lower part of the device toward the mounting rail until the mounting rail holder engages.
 - The device is now mounted on the mounting rail.

Figure 4 : Mounting on DIN rail

3.2 Dismounting

⚠ WARNING

DANGER OF BURNS

Depending on the ambient conditions, the housing temperature can reach very high temperatures.

- Do not touch the housing of the device during operation.
- Once the device has been disconnected from the power supply, do not touch the housing until it has cooled down for a few minutes.

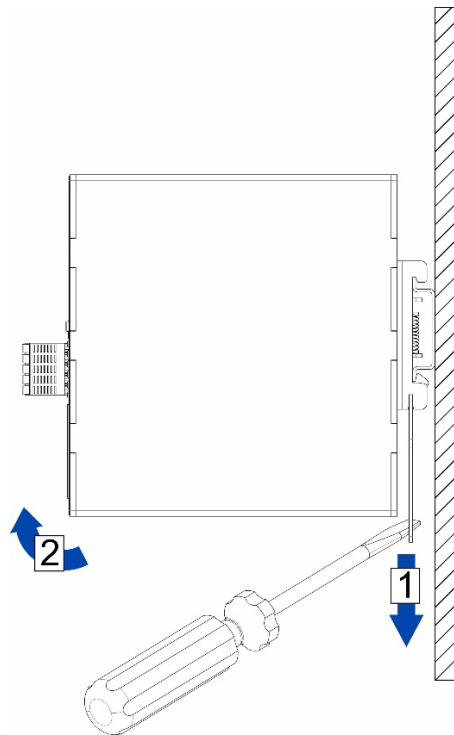

Figure 5 : Dismounting from DIN rail

- 1 Pull down the DIN rail adapter on the back of the housing with a screwdriver.
- 2 Release the bottom of the device from the mounting rail.
- 3 Lift the device up and off the mounting rail.

3.3 Mounting positions

The DUSH DC-UPS can be mounted on the DIN rail in the following positions.

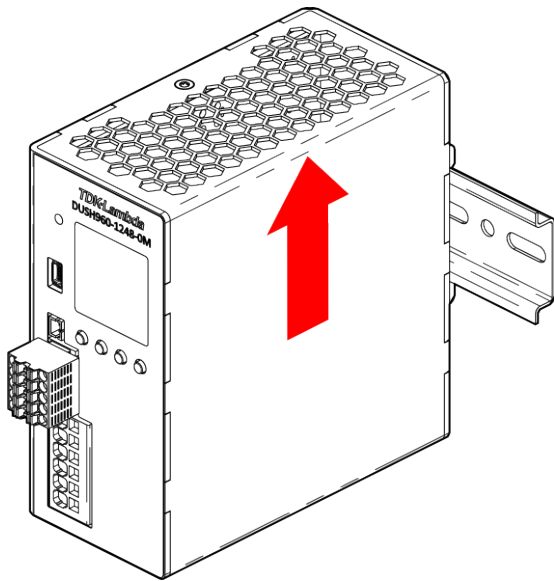

Figure 6 : Recommended mounting position

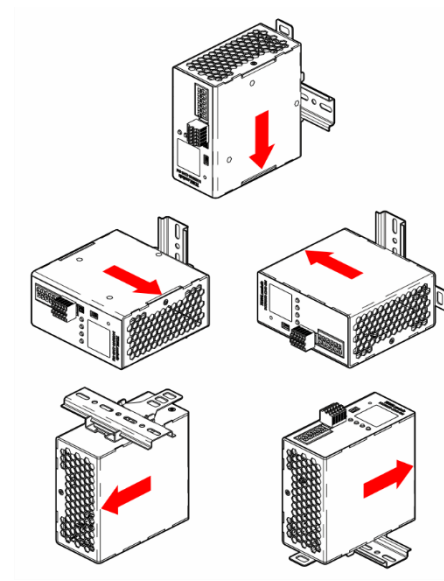

Figure 7 : Optional mounting positions

NOTICE

Available output power and derating values can be found in the technical specification
→ emea.lambda.tdk.com/dush-series.

3.4 Installation clearance / Cooling

Installation clearances			
Vertically (Z axis)			
Top side	1	min. 40mm (1 ³⁷ / ₆₄ in)	installation above heat sources not permitted
Bottom side	2	min. 20mm (2 ⁵ / ₃₂ in)	
Horizontally (X axis)			
Left side / Right side	3a 4a	min. 15mm (1 ⁹ / ₃₂ in)	to heat sources (same power rating) to passive components
Left side / Right side	3b 4b	min. 2mm (5 ⁵ / ₆₄ in)	

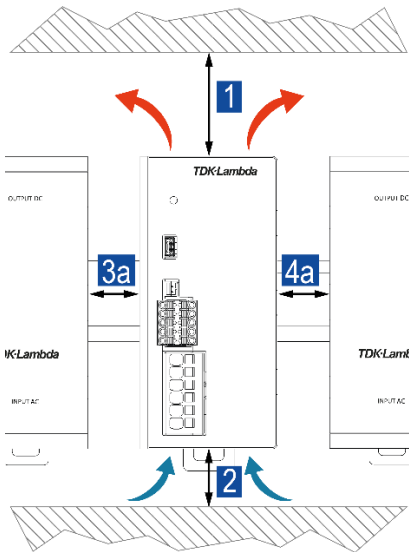

Figure 8 : Installation clearances to heat sources

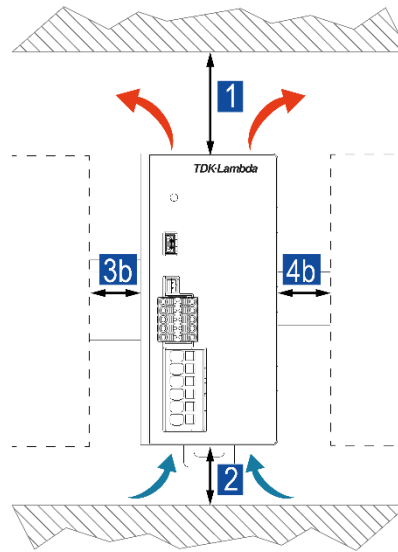

Figure 9 : Installation clearances to passive components

NOTICE

Convection cooled system.

All values refer to normal mounting position. (In this position, the front of the product faces into direction of the Y-axis.)

4 Connection / terminal blocks / interfaces

- Use an appropriately sized power supply, which can deliver the additional required internal current consumption of the DUSH DC-UPS and the required current for charging the batteries. Use power supplies that do not deliver more than 20 A continuous output current (check max. current input).
- Switch/Circuit-breaker mounting position:
 - Input path: A DC-type switch or circuit-breaker must be mounted near the power supply. The current rating depends on the power supply, wire length and cross section.
 - Battery path: A DC-type switch or circuit-breaker must be mounted near the battery. The current rating depends on the power supply, wire length and cross section.

4.1 Terminal blocks 1.x (IN/OUT/BATT)

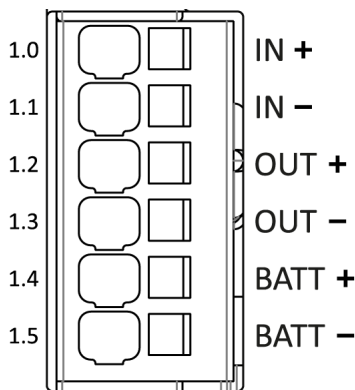





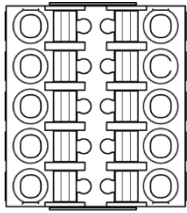

Figure 10 : Terminal block 1.x

	Ø [AWG]	24 ... 11
	Ø [mm ²]	0.2 ... 4.0
	Ø [AWG]	24 ... 11
	Ø [mm ²]	0.2 ... 4.0
	Ø [mm ²]	0.25 ... 2.5
	Ø [mm ²]	0.25 ... 2.5
	L [in]	$\frac{25}{64} \dots \frac{15}{32}$
	L [mm]	10 ... 12
Screwdriver	[in]	SL $\frac{1}{32} \times \frac{9}{64}$
	[mm]	SL 0.6 × 3.5

4.2 Terminal blocks 2.x (MB-RTU/AUX/R1/R2/INH)



RL1	2.0	2.1	RI2
GND	2.2	2.3	RL COM
MB RTU A	2.4	2.5	INH -
MB RTU B	2.6	2.7	INH +
AUX -	2.8	2.9	AUX +

Figure 11 : DUSH960-1248-0M

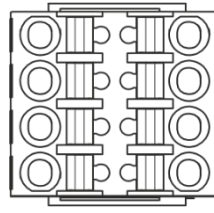

RL1	2.0	2.1	RI2
GND	2.2	2.3	RL COM
MB RTU A	2.4	2.5	INH -
MB RTU B	2.6	2.7	INH +

Figure 12 : DUSH960-1248-1M

	Ø [AWG]	28 ... 16
	Ø [mm ²]	0.2 ... 1.0
	Ø [AWG]	28 ... 16
	Ø [mm ²]	0.2 ... 1.5
	Ø [mm ²]	0.25 ... 0.75
	Ø [mm ²]	0.25 ... 1.0
	L [in]	5/16 ... 23/64
	L [mm]	8 ... 9
Screwdriver	[in]	SL 1/64 × 1/8
	[mm]	SL 0.5 × 3.0

4.3 Connector 3.0, Temp. Sensor

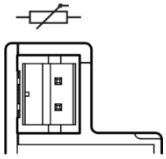

Figure 13 : Connector for temperature sensor

One of the following temperature sensors can be connected to the device:

- ACC-DUSH-DTX01-0X: 10 kOhm NTC sensor, with plug connector, cable length 1 m
- ACC-DUSH-DTX02-0X: 10 kOhm NTC sensor, with plug connector, cable length 2 m

4.4 Connector 4.0, USB connection for Power CMC

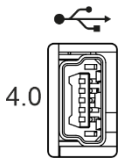

Figure 14 : Mini-USB port

Via the Mini-USB port the device can be connected to a PC.

NOTICE

The adapter cables are not included in the scope of delivery.

5 Functional description

5.1 Battery health monitor

The battery health monitor is composed of:

- Internal resistance measurement: The resistance is periodically measured. The internal resistance is a good indicator of the battery health status; a sudden increase of the internal resistance indicates a potential problem on the battery or on the battery wiring.
- Temperature measurement: The battery temperature is monitored through an optional temperature sensor (P/N: ACC-DUSH-DTX01-0X / ACC-DUSH-DTX02-0X). The battery charger considers the battery temperature and provides a temperature compensated charging voltage. In case of over or under temperature the system disconnects the battery to prevent damage.
- Coulomb counter: Estimates the remaining battery capacity and consequently the available backup time.
- Deep discharge protection: It protects against the deep discharge of the battery which can lead to its irreversible damage.

The battery internal resistance (R_i) is measured by draining a defined AC current through an active load (AL) from the battery and measuring the AC voltage drop across the load terminals. The principle is represented in the following figure.

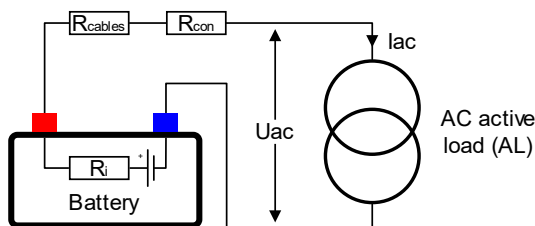

Figure 15 : Internal resistance measurement

The measured resistance is the sum of the battery internal resistance, the cables resistance and the connectors resistance, therefore cabling problem such as loose connectors are also detected with R_i measurement.

When high-capacity batteries and/or small and long cables are used $R_{cables}+R_{con}$ may be $> R_i$.

5.2 Battery charger

NOTICE

For Lithium cells the balancing and protection circuit must be included in the battery pack.

For Nickel batteries the use of the external temperature sensor is mandatory. The sensor must be placed in contact with the battery.

The battery charger supports various chemistries such Lead-Acid, Nickel, Lithium and Supercapacitors. The charging algorithm for each chemistry is given below. Other charging algorithms can be implemented by request (contact factory).

The battery charger automatically reduces the current to avoid exceeding the maximum input current in case of high current load.

The user must set the following parameters to allow the charger to perform correctly (→ 6.3 SETTINGS):

- Battery type
- Battery charge voltage
- Battery charge current
- Battery float voltage

The battery charge terminates in case at least one of the following conditions are satisfied:

- **Low current:** The measured battery charge current is lower than 10% of the “Battery charge current” while the measured voltage is at least 98% of the “Battery charge voltage”.
- **Timer:** the charge is terminated after the battery has been charged for a predetermined amount of time. The value is automatically calculated by the device.

For Nickel batteries only, the following conditions are also checked:

- **Temperature Cutoff (TCO):** The battery temperature is higher than the “Battery maximal temperature” (→ 6.36.3 SETTINGS) minus 3 °C for more than one minute. For example, if the maximal battery temperature is set to 60 °C, the charge terminates in case the temperature is higher than 57 °C.
- **Rate of Temperature Increase ($\Delta T/dt$):** The battery temperature is rising at a rate equal or superior to 1°C/min. To avoid unattended end of charge do not place the system on an ambient with rapid changes of temperature (for example exposed to direct sunlight).

The charger voltage is independent on the input voltage (power supply) and is user settable.

Lead acid and lithium batteries share the same 3 stages charging algorithm as shown on the following figure.

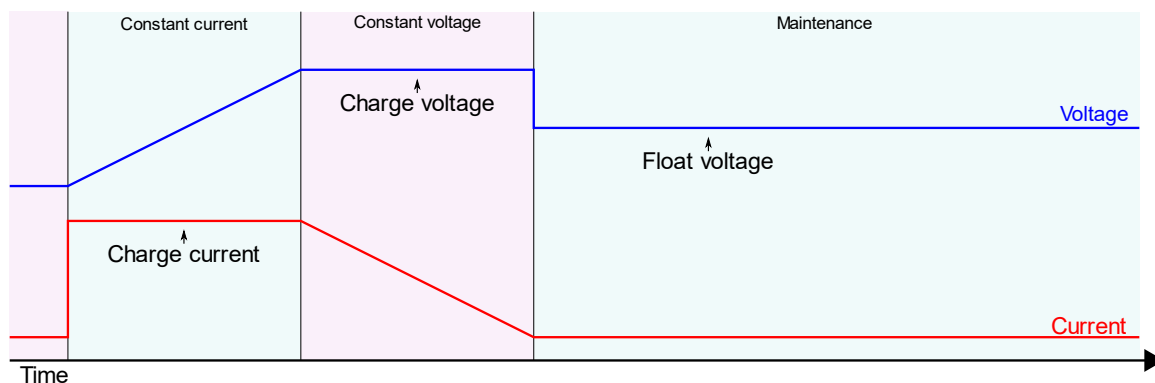

Figure 16 : Lead acid and Lithium charging algorithm

For nickel batteries, during maintenance, the DUSH960-1248-xM gives pulses of 3 s every 30 s with a maximum current of 1/10 of “Battery charge current” and maximum voltage equal to “Battery charge voltage”.

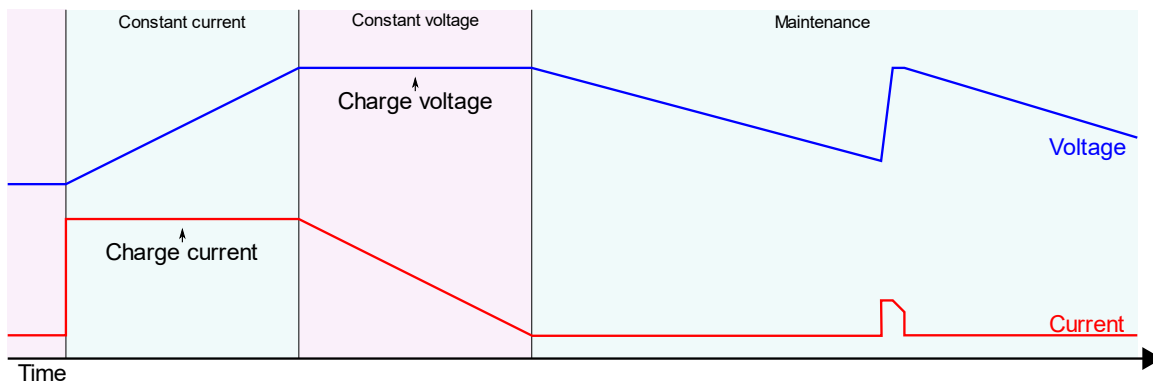

Figure 17 : Nickel charging algorithm

For Supercapacitor after the constant current phase the algorithm goes directly to maintenance keeping the voltage at “Battery charge voltage”.

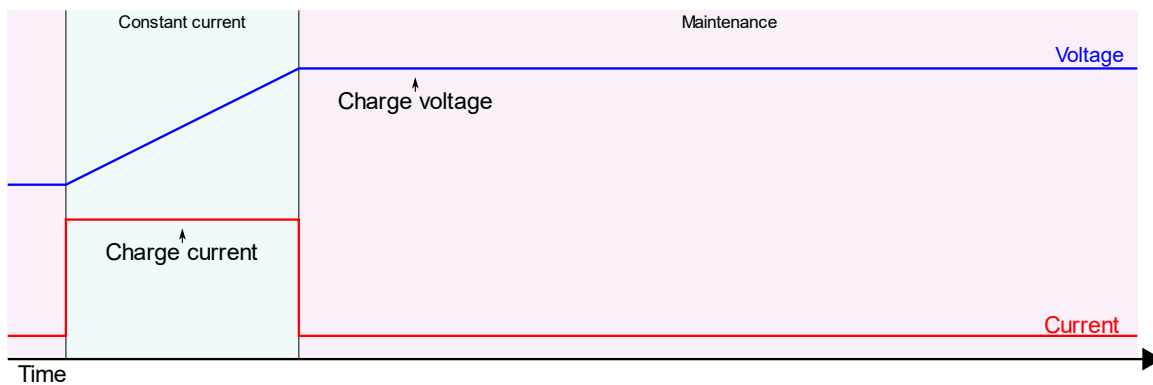

Figure 18 : Supercapacitors charging algorithm

5.3 Coulomb counter

DUSH960-1248-xM measures the current flowing from / to the battery to keep track of the capacity available on the battery. The capacity is measured in Ampere Hour [Ah]. The value shown is based on the following assumptions:

- The value shown is just informative and does not represent the real state of charge of the battery in some circumstances, for example if the battery is damaged.
- When the battery is connected for the first time or the system starts from OFF, the system assumes the battery is fully discharged and start with 0 Ah counter.
- Once the battery is fully charged the system sets the counter to the nominal capacity specified by the user (→ 6.3 SETTINGS).

5.4 PC shutdown and automatic restart

PC shutdown: In case the DUSH960-1248-xM is used to supply a PC it is possible to automatically shut down the PC after an adjustable time of backup. For this the PC must run the PowerCMC application (provided free) and must be connected through Modbus. Optionally PowerCMC can call a task on the PC before shutting down, for example to back up some sensitive data.

Automatic restart: DUSH960-1248-xM can automatically restart a PC which was powered OFF by mistake, for example in case of the Operating System (OS) crash. The user may adjust an output current threshold, and a timer used for detecting the PC OFF status. In order to restart the PC, the DUSH960 1248 xM toggles the output OFF and then ON again. User must enable in the PC BIOS the automatic start in case of supply ON.

The diagram below shows the DUSH960-1248-xM behavior when Shutdown and automatic restart is enabled.

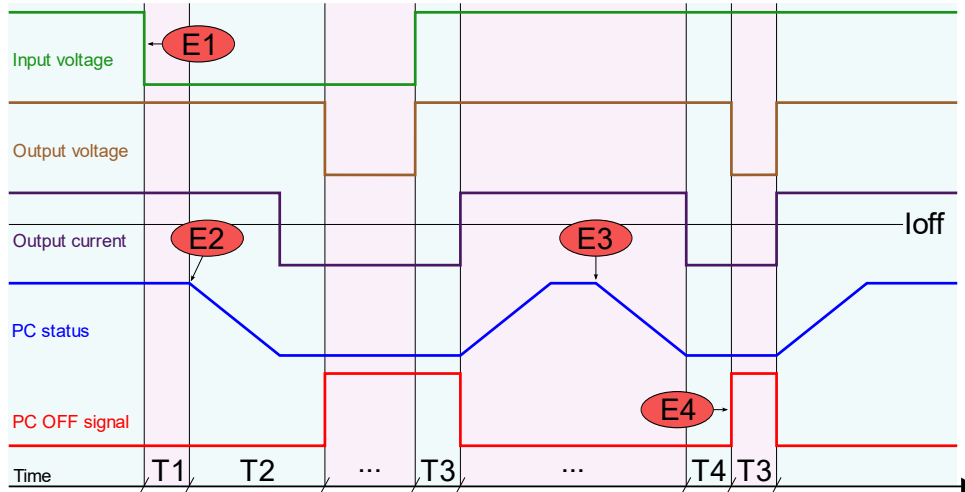

Figure 19 : Shutdown and restart chart

Parameter	Name	Description
E1	Backup	Power failure on the line happens. System enters backup mode.
E2	Automatic PC shutdown	The PowerCMC sends a shutdown command to the PC. Optionally: a task is called before shutdown.
E3	Unexpected PC shutdown	The PC shutdowns in an unexpected way, for example caused by OS crash.
E4	PC restart	DUSH960-1248-xM detects the PC being OFF because the output current was lower than I _{off} current threshold for T ₄ time. Therefore, DUSH960-1248-xM generates an ON > OFF > ON cycle on its output.
T1	PC shutdown delay	User settable (→ 6.3 SETTINGS). Time between start of backup and start of PC shutdown procedure.
T2	PC shutdown time	User settable (→ 6.3 SETTINGS). Time between start of shutdown procedure and output voltage OFF. This time must be set longer than the maximum time the PC takes to complete the shutdown.
T3	PC restart minimum OFF time	User settable (→ 6.3 SETTINGS). T ₃ is the delay used between the return of the input voltage and the activation of the output. The same time is used by the automatic restart function as power OFF time to restart the PC. The value must be big enough for the

Parameter	Name	Description
		PC to detect the supply ON > OFF > ON cycle to restart.
T4	PC OFF detection timer	User settable (→ 6.3 SETTINGS). Minimum time at which the output current must be below the Ioff current threshold to trigger the automatic PC restart (PC supply ON > OFF > ON cycle).
Ioff	PC OFF detection current threshold	User settable (→ 6.3 SETTINGS). Current threshold used to detect PC OFF status. This value must be lower than the minimum PC current consumption when this is ON.

The parameters are settable through the DUSH960-1248-xM user interface or using the PowerCMC application. The checkbox “Run on startup” must be checked on PowerCMC when PC shutdown function is used. To inhibit the software from calling the shutdown command user can select the “Inhibit shutdown” check box.

5.5 Cold start

The cold start is a procedure that allows turning ON the UPS without the input power. This procedure is used to turn ON the UPS to operate during a power interruption. This practice is also a method to see if the battery connected to the DUSH960-1248-xM is functional.

In cold start the DUSH960-1248-xM will remain ON for at least 60 seconds independently from the battery voltage (even when being under the deep discharge threshold), the inhibit input and the backup timer. After the first 60 seconds the device stays ON until the battery is not deep discharged, the backup timer is not expired or the inhibit input is not active.

When cold started, the “Cold start” text is written beside the input icon on the status screen. If the input supply returns during cold start the device reverts to normal operation.

To cold start the device the user as the following options:

- **From front panel:** Press and hold simultaneously the and buttons until you see the welcome message on the screen.
- **Remotely through inhibit input:** When enabled on the user settings (→ 6.3 SETTINGS), the device cold starts toggling the inhibit status from true to false.
- **On battery connection:** When enabled on the user settings (→ 6.3 SETTINGS), the device automatically cold starts when the battery, previously disconnected, is connected to the device.

Please, take in account that the battery connection can take up to 5 seconds to be detected and the inhibit state can take up to 3 seconds to be changed when in low power mode.

5.6 Battery Cycling

When this option is enabled the device schedules and activates a periodic battery discharge on a user settable day and time of the week. The user can select after how many weeks the system repeats the cycle. The purpose of this function is to verify the battery capacity/health.

The parameters related to this function are (→ 6.3 SETTINGS):

- **Battery cycle**
Enables or disables the function
- **Battery cycle every**
Indicates the time in weeks between two scheduled cycles
- **Battery cycle day**
Indicates the day of week on which perform the battery cycling
- **Battery cycle hour**
Indicate the hour at which start the battery cycling
- **Battery cycle minute**
Indicate the minute at which start the battery cycle
- **Battery cycle SoC threshold**
Indicate the state of charge in % at which the battery cycling must stop
- **Battery cycle time threshold**
Indicates the time, specified in minutes, from the start of battery cycling after which the process must stop

Into the device's menu SETTINGS the parameters "Battery cycle hour" and the "Battery cycle minute" are grouped into the "Battery cycle time" field. Any time one of those parameters is modified or a start-up is performed the battery cycle scheduling is recalculated.

The process is scheduled at time specified by "Battery cycle hour" and "Battery cycle minute" parameters at the first available day specified by "Battery cycle day" parameter. Once the scheduled day and time are reached the battery cycle starts and the next event is scheduled at the same day, at the same time but after the number of weeks specified by "Battery cycle every" parameter.

When the battery cycle is in progress into the device's menu STATUS, at the top, the "Scheduled bat. disc." message is shown. The battery cycle in progress message is shown into the field "Next battery cycle" of the device's menu

INFO, and into the tab Status of the PowerCMC application.

The battery cycle is ended when one of the thresholds, specified by “Battery cycle SoC threshold” and by “Battery cycle time threshold”, is reached. Once the programmed battery cycle process terminates the device turns back to nominal function.

If the scheduled battery cycle should start while the battery is charging, the battery cycle is skipped to permit to the battery a full recharge.

In case that the battery cycle is in progress and the input under voltage state is detected the battery cycle is immediately interrupted for preserve the battery charge in case of issues on the line. If there is a need to interrupt an ongoing battery cycle process, there are three methods.

- The first method is disabling the battery cycle function through the device’s menu SETTINGS by setting the “Battery cycle” field as “Disabled”.
- The second method is disabling the battery cycle function through the Modbus field “Battery cycle” setting field as “Disabled”.
- The third method is stopping the current battery cycle through the Modbus field “Battery cycle stop”.

User can manually start the cycle using the Modbus field Battery cycle start, this will not affect the automatic scheduling. When starting manually, the cycle starts regardless of the battery status (e.g. battery charging).

The information about the next battery cycle is shown in the device’s menu

INFO under “Next battery cycle” or through Modbus field “Next battery cycle”.

Below a list of the LOGS and DUSH System Events related to this function:

Battery cycle active

	Primary value	Secondary value
0	Battery cycle ended	Minimum battery voltage during the battery cycle
1	Battery cycle started	Battery voltage at start of battery cycle

Battery cycle triggered by

	Primary value	Secondary value
1	Schedule	Not used
2	User	Not used

Battery cycle ended by

	Primary value	Secondary value
1	State of charge (SoC)	Not used
2	Time limit	Not used
3	Input UV (under voltage)	Not used
4	Battery in charge	Not used
5	User	Not used

5.7 Current limit

DUSH960-1248-xM can limit the current flowing through its input, output and battery terminals to a user settable threshold.

The DUSH960-1248-xM provides 4 different settings for the current limit (→ 6.3 SETTINGS):

- **Maximum input current**, default 20 A: it is used to limit the input current at a specified threshold. For example, if the DC power supply is rated less than 20 A the threshold can be lowered to avoid too high current drain from the power supply. When the input current limit is reached, the battery charging current is limited; if the input current cannot be kept below the threshold due to excessive loading an input overcurrent alarm is triggered. When the input current is approaching the threshold, the measured input current is displayed with red fonts on the LCD.
- **Maximum output current**, default 20 A: it is used to limit the maximum current delivered to the load. When the threshold is reached due to excessive loading an output overcurrent alarm is triggered. When the output current is approaching the threshold, the measured output current is displayed with red fonts on the LCD.
- **Battery maximum charge current**, default 0.5 A (maximum settable 20 A): it is used to limit the maximum charge current supplied to the battery. This threshold will be automatically reduced in such manner that the maximum input current limit is distributed to the load with priority towards the charging.
- For example, if the maximum input current limit is 20 A and the load needs 10 A while the maximum charge current is set at 12 A, the controller will limit the charging current automatically to 10 A until the load will need < 10 A.
- **Battery maximum discharge current**, default 20 A: it is used to limit the maximum discharge current delivered from the battery during the backup function. When the threshold is reached due to excessive loading a battery overcurrent alarm is triggered and the output voltage starts to decrease. When the

battery discharge current is approaching the threshold, the measured battery current is displayed with red fonts on the LCD.

5.8 Shutdown and reset on request

The device offers the on request reset or shutdown feature. There are two mode of reset/shutdown requests, the immediate and the delayed (→ 6.3 SETTINGS):

- The first mode starts the shutdown/reset sequence immediately after a “Shutdown” or “Reset device” Modbus command is received by the DUSH960-1248-xM.
- The second mode starts the shutdown/reset sequence with a delay specified through Modbus fields “Delayed device shutdown time” and “Delayed device reset time”.

Generally, the shutdown command is used to interrupt the ongoing backup process and to send the device into low power mode. The reset command performs the reboot of the device, with the same effect as a device power cycle.

6 Operating

6.1 Menu structure

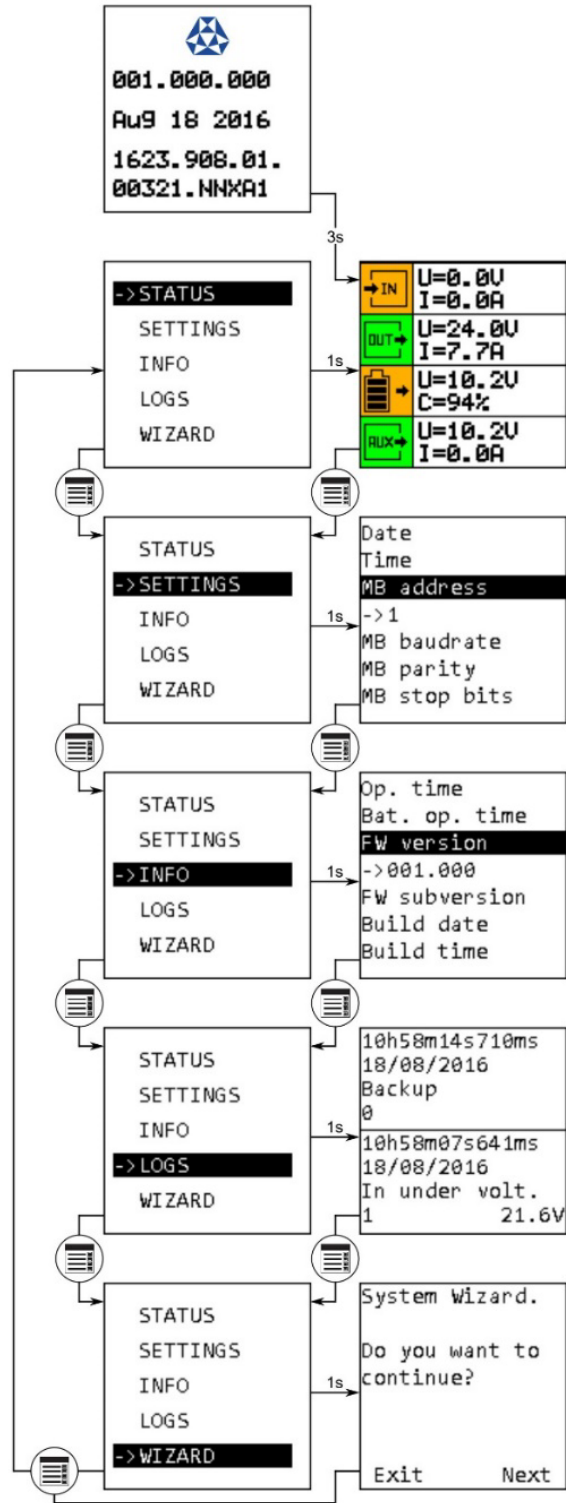

Figure 20 : Menu structure

6.2 STATUS

The status screen shows the measurement and statuses to ease the system diagnostic.

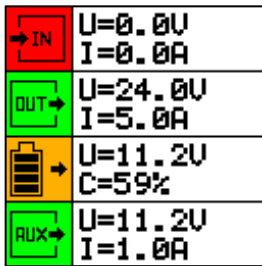

Figure 21 : UPS status screen

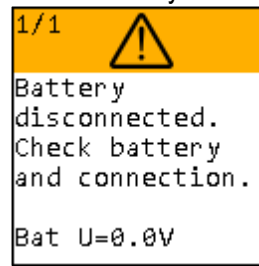

Figure 22 : Warning screen

The screen is divided into sections, which are identified by the symbols and values shown in the following table:

Display item	Name	Function
U=24.0V I=7.7A	Input	Shows the measured input voltage and current
U=24.0V I=7.7A	Output	Shows the measured output voltage and current
U=10.2V C=94%	Battery	Shows the battery voltage, current, temperature, resistance and charge
U=10.2V I=0.0A	Auxiliary	Shows the measured auxiliary output voltage and current

For each section the icon background color reflects its status.

- Green = Values within the predefined parameters
- Orange = charging/discharging battery or delayed shutdown/restart status
- Red = values are within the predefined parameters

Symbol	Name	Function
	Input OK	Input voltage is within the predefined parameters, DUSH in normal operation
	Input failure	Input voltage is outside the predefined parameters, DUSH in backup mode
	Output OK	Output voltage is present and within the predefined parameters
	Output failure	Output voltage is outside the predefined parameters, load is not powered
	Battery OK	Battery is fully charged and has reached the float voltage
	Battery charging	Battery is charging until 100% SoC is reached. The number of bars drawn inside reflects the charge status.
	Battery discharging	Battery is discharging, load is powered from the battery. The number of bars drawn inside reflects the charge status.
	Battery error	A battery error has occurred
	Auxiliary OK	Auxiliary output is within the predefined parameters
	Auxiliary failure	Auxiliary output is outside the predefined parameters

6.3 SETTINGS

The setting menu contains all the configurable parameters available to the user. Use the UP/DOWN KEY to navigate through the menu items. Press the OK KEY to enter and exit the editing mode, exiting the edit mode stores and activates the new configuration. While in editing mode use the UP/DOWN key to change the selected value. All settings are also accessible via Modbus at the specified address.

The locking/unlocking of the settings editing can be done using the field “Lock settings” into the menu SETTINGS or through the Modbus “Lock settings” field.

The locking/unlocking of the settings editing can also be done keeping pressed simultaneously the UP and DOWN keys for at least 3 seconds while into the menu SETTINGS. There are no notifications using this procedure.

When the lock is active, trying to edit a parameter using the device’s buttons shows a “Settings Locked” message for a couple of seconds. It is always possible to edit the setting through Modbus regardless the status of the lock.

Parameter	Description	Range/Value
Modbus address	Set the used Modbus address for the DUSH (RS485)	1 ... 247
Modbus baudrate	Choose the Modbus baudrate used in the Modbus network on site (RS485)	9600, 19200, 38400, 57600, 15200
Modbus parity	Choose the Modbus parity used in the Modbus network on site (RS485)	None, Even, Odd
Modbus stopbits	Choose the stopbits used in the Modbus network on site (RS485)	1 stop bit, 2 stop bits
Bat. type	Choose the battery type used with the DUSH	Lead, Nickel, Lithium, SuperCap
Bat. charge U	Set the battery charge voltage for the connected battery (see battery datasheet)	10.0 ... 58.0 V DC
Bat. charge I	Set the battery charge current for the connected battery	0.5 ... 20.0 A
Bat. float U	Set the battery float voltage for the connected battery (see battery datasheet)	10.0 ... 58.0 V DC
Bat. low U	This value is used for the “Bat. Low” alarm (also available on the two alarm relays) which turns active when the battery voltage is under the “Battery low voltage” threshold.	5.0 ... 58.0 V DC
Bat. deep disch. U	Set the deep discharge voltage for the connected battery (see battery datasheet)	5.0 ... 58.0 V DC
Bat. max disch. I	Set the battery maximum discharge current for the connected battery	5.0 ... 21.0 A
Bat. capacity	Set the total capacity for the connected battery or supercap in Ah or Farad. When calculating the total capacity, batteries and strings connected in parallel must be considered	1 ... 1000 Ah/F
Bat. min. T	Set the minimum temperature for the connected battery (see battery datasheet). This value is used as threshold for the “Battery under temperature” alarm.	-40 ... 60 °C

Parameter	Description	Range/Value
Bat. max. T	Set the maximum temperature for the connected battery (see battery datasheet). This value is used as threshold for the "Battery under temperature" alarm.	-40 ... 60 °C
Bat. lifetime	Set the maximum battery lifetime regarding to the battery manufacturer (see datasheet of the battery). This value is used as threshold for the "Battery lifetime elapsed" alarm.	1 ... 100,000 h
Ri mode	Set the mode of operation for the "Battery Ri too high" alarm. This alarm turns active when the measured battery internal resistance exceeds the alarm threshold.	Disabled, Fix, Automatic, Auto. done
Ri nominal	Set the nominal value for the internal resistance of the connected battery (see battery datasheet)	0 ... 300 mΩ
Ri max. variation	Set the maximum variation for the internal resistance alarm in percentage according to the Ri nominal value. This value is used for the threshold calculation of the "Battery Ri too high" alarm.	50 ... 300 %
Bat. installation date	This installation date is used to calculate the battery lifetime. If the battery lifetime exceeds the "Battery lifetime" value, the "Battery lifetime elapsed" alarm activates.	10d 02m 2024y (10. February 2024)
Bat. charge cycles	This shows the number of charge cycles for the connected battery. The value increments automatically at the end of a battery charge cycle. It can be set according to the installed battery if this was already used, and the former charging cycles are known.	0 ... 65535 cycles
Max. input I	Set the maximum input current of the DUSH. The input current is limited to the value set. The battery charging current will be reduced if necessary. This is used accordingly to the max. output current of power supply used on the input of the DUSH.	1.0 ... 21.0 A
Output nominal U	Set the nominal output voltage of the DUSH. The DUSH enters backup mode when the output voltage drops below 90% of the nominal value set, it is also the regulated output voltage during backup. Due to the internal buck-boost converter the nominal output voltage can be different to the battery voltage. It must correspond to the voltage of the power supply unit used on the input.	10.0 ... 58.0 V DC
Max. output I	Set the maximum output current of the DUSH.	5.0 ... 21.0 A

Parameter	Description	Range/Value
	The DUSH limits the maximum output current to this value reducing the output voltage if necessary. It must correspond and not exceed the max. output current of the power supply unit used on the input.	
Backup time enable	If enabled the DUSH shuts down if the backup last more than the “Max. backup time” value	Disabled, Enabled
Backup time max.	If the function “Backup time enable” is set to “Enabled” the DUSH shuts down if the backup last more than the specified backup time max.	1 ... 1,440 min
Buzzer enable	Only for DUSH960-1248-0M Enable/Disable buzzer sound in case of alarm.	Disabled, Enabled
Relay 1	Set the alarms signaled on the alarm relay 1.	→ 6.4 System alarms
Relay 2	Set the alarms signaled on the alarm relay 2.	→ 6.4 System alarms
Inhibit polarity	Set the active polarity of the inhibit input. See chapter “Remote ON/OFF” for more information about the inhibit function.	Low, High
Output enable	Enable/Disable the output of the DUSH.	Disabled, Enabled
Aux enable	Enable/Disable the auxiliary output of the DUSH.	Disabled, Enabled
CS on inhibit	Enable/Disable the cold start on inhibit toggle. When enabled, the device cold starts from the battery without an input voltage by toggling the inhibit input status from true to false.	Disabled, Enabled
CS on battery	Enable/Disable the cold start on battery connection. When enabled on the user settings, the device automatically cold starts when the battery, previously disconnected, is connected to the device.	Disabled, Enabled
PC shutdown enable	Enable/Disable the “PC shutdown” function of the DUSH in combination with the PowerCMC software. → 5.4 PC shutdown and automatic restart	Disabled, Enabled
PC restart enable	Enable/Disable the “PC restart” function of the DUSH in combination with the PowerCMC software. → 5.4 PC shutdown and automatic restart	Disabled, Enabled
PC shutdown delay	Set the delay time for the “PC shutdown” function of the DUSH in combination with the PowerCMC software.	1 ... 3,600 s

Parameter	Description	Range/Value
	→ 5.4 PC shutdown and automatic restart	
PC shutdown time	Set the shutdown time for the “PC shutdown” function of the DUSH in combination with the PowerCMC software. → 5.4 PC shutdown and automatic restart	1 ... 600 s
PC restart time	Set the minimum off time before restart for the “PC shutdown” function of the DUSH in combination with the PowerCMC software. → 5.4 PC shutdown and automatic restart	1 ... 60 s
PC OFF I	Set the PC off detection current threshold for the “PC shutdown” function of the DUSH in combination with the PowerCMC software. → 5.4 PC shutdown and automatic restart	0 ... 20 A
PC OFF time	Set the PC off detection timer for the “PC shutdown” function of the DUSH in combination with the PowerCMC software. → 5.4 PC shutdown and automatic restart	1 ... 60 s
Blink out enable	When this option is enabled, during backup, the output voltage switches on/off periodically with the timing defined on “Blink output on backup Ton” and “Blink output on backup Toff”. This function may be used on illumination application where is necessary to inform the person in the building that the lighting is running on batteries.	Disabled, Enabled
Blink out Ton	Set the Ton time for the “Blink output on backup” function. This value defines how long the illumination will be on whilst blinking.	10 ... 600 s
Blink out Toff	Set the Toff time for the “Blink output on backup” function. This value defines how long the illumination will be off whilst blinking.	0.1 ... 60 s
Out SC latch enable	Disable/Enable the output short circuit latch. When enable the device disables the output when a short circuit is detected on the output. To restart the output the operator must press the “OK” button from the front panel.	Disabled, Enabled
Out SC detection th.	Set the Output short circuit detection voltage threshold. By default, the output short circuit is detected only if the residual voltage on the output pins is < 3 V. In some application where long cables are connected to the output, if a short circuit is applied at the end of the cable, the residual voltage on the connector may be > 3 V.	3 ... 58 V DC

Parameter	Description	Range/Value
	In this case, increasing the detection threshold, ensures the short circuit is detected.	
High inrush enable	Disable/Enable the usage of the DUSH on loads with high inrush current. When enable, the unit send a higher current pulse when the output is switched on, to withstand loads with a high start-up inrush current.	Disabled, Enabled
Not ready SoC th	Sets the state of charge threshold for the "UPS not ready" alarm. The alarm is active when the "UPS not ready SoC threshold" is undercut. The state of charge value of the connected battery is calculated in the DUSH and is stated as a percentage.	10 ... 90 %
Near empty SoC th	Sets the state of charge threshold for the "UPS near" alarm. The alarm is active when the "UPS near empty SoC threshold" is undercut. The state of charge value of the connected battery is calculated in the DUSH and is stated as a percentage.	10 ... 90 %
Lock settings	Set the lock functions of the DUSH front panel. When enabled, the possibility to modify any device setting through the device's menu SETTINGS is disabled. The shortcut for toggle the value of this field is to keep pressed at the same time the (Up) and (Down) buttons for at least 3 seconds when you are in the menu Fehler! Verweisquelle konnte nicht gefunden werden..	Disabled, Enabled
Delayed shdn time	Set the delayed device shutdown time of the DUSH. It specifies the time delay between the shutdown command and its execution.	1 ... 600 s
Backup start th	Set the backup start threshold of the DUSH. It specifies the input voltage, expressed as percentage of output nominal voltage, at which the backup starts.	80 ... 95 %
Batt. revive interval	Specifies the interval between LiFePo4 revive impulses	3 ... 60 s
Battery cycle	Disable/enable the battery cycle function on the DUSH. When enabled the device schedules and activates an periodic battery discharge based on day of week, time, and periodicity. → 5.6 Battery Cycling	Disabled, Enabled

Parameter	Description	Range/Value
Battery cycle every	Defines the intervals at which the battery cycle function is executed in weeks. → 5.6 Battery Cycling	1 ... 52 weeks
Battery cycle day	Specifies on which day of the week the battery cycle should be performed. → 5.6 Battery Cycling	Monday, Tuesday, Wednesday, Thursday, Friday, Saturday, Sunday
Battery cycle time	Specifies at which hour and minute of the day the battery cycle should be performed. → 5.6 Battery Cycling	0 ... 23 h 0 ... 59 m
Battery cycle SoC th	Specifies at which state of charge the battery cycle must be stopped. The state of charge value of the connected battery is calculated in the DUSH and is stated as a percentage. → 5.6 Battery Cycling	0 ... 90 %
Battery cycle time th	Specifies after how many minutes from start the battery cycle must be stopped. → 5.6 Battery Cycling	1 ... 1,440 min
Date	Set the current Date.	10d 02m 2024y (10. February 2024)
Time	Set the current Time.	10h 45m 55s (10:45:55)

6.4 System alarms

Alarm	Description	Value
NO	Relay contact normally open → table below	Y/N
Backup	Alarm: Backup	Y/N
SOC 25%	Alarm: Battery SoC < 25 %	Y/N
Life time	Alarm: Battery life time elapsed	Y/N
Ri too high	Alarm: Battery Ri too high	Y/N
Bat. low	Alarm: Battery low	Y/N
Bat. disc.	Alarm: Battery disconnected	Y/N
Bat. fail	Alarm: Battery charge failure	Y/N
Backup 25%	Alarm: Backup time left < 25 %	Y/N
UPS not ready	Alarm: UPS not ready	Y/N
UPS near empty	Alarm: UPS near empty	Y/N
Internal failure	Alarm: Internal failure	Y/N

Normally open	1 or more enabled alarm state active	Relay contact status
True	No	Open
True	Yes	Closed
False	No	Closed
False	Yes	Open

6.4.1 DUSH System Alarms

Alarm	LCD name	Description
Backup	Backup	Active when the system is in backup mode
Battery SoC < 25%	Bat. SoC < 25%	Active when the battery State of Charge is under 25 % of the nominal full charge capacity.
Battery life time elapsed	Bat. lifetime elapsed	Active when the actual calculated battery lifetime exceeds the threshold specified in the "Battery lifetime" setting
Battery Ri too high	Bat. Ri too high	Active when measured battery internal resistance exceed the alarm threshold
Battery low	Bat. low	Active when the measured battery voltage is under the threshold specified in the "Battery low voltage" setting
Battery disconnected	Bat. disconnected	Active when no battery is detected by DUSH. The detection of the battery disconnection can take up to 40s when the battery is in charging state and up to 20s when the battery is in float state.
Battery under temperature	Bat. under temperature	Active when the battery measured temperature (using the optional external temperature sensor ACC-DUSH-DTX01-0X (1m) or ACC-DUSH-DTX02-0X (2m)) is under the threshold specified in the "Battery min. temperature" setting. If active the battery charger is disabled.
Battery over temperature	Bat. over temperature	Active when the battery measured temperature (using the optional external sensor ACC-DUSH-DTX01-0X (1m) or ACC-DUSH-DTX02-0X (2m)) exceed the threshold specified in the "Battery max. temperature" setting. If active the battery charger is disabled.

Alarm	LCD name	Description
Battery charge failure	Bat. charge fail	Active when DUSH could not charge the battery correctly. When active, the battery charger is disabled. Disconnect the battery to reset the alarm.
Battery over discharge current	Bat. over discharge I	Active when the measured battery discharge current reaches the threshold specified in the "Battery max. discharge current" setting
Battery deep discharged	Bat. deep discharge	Active when the battery measured voltage is under the threshold specified in the "Battery deep discharge voltage" setting
Backup time left < 25%	Backup time left < 25%	Active when the system is in backup and the maximal backup time is less than the "Max. backup time" setting
UPS not ready	UPS not ready	Active when the "UPS not ready SoC threshold" is undercut.
UPS near empty	UPS near empty	Active when the "UPS near empty SoC threshold" is undercut.
Input under voltage	Input under voltage	Active when the measured input voltage is under 90 % of the "Nominal output voltage" setting
Input over voltage	Input over voltage	Active when the measured input voltage exceeds 120 % of the "Nominal output voltage" setting
Output under voltage	Output under voltage	Active when the measured output voltage is under 90 % of the "Nominal output voltage" setting
Output over voltage	Output over voltage	Active when the measured output voltage exceeds 120 % of the "Nominal output voltage" setting
Output overload	Output overload	Active when the measured output current reaches the threshold specified in "Max. output current" setting
Input over current	Input over current	Active when the measured input current reaches the threshold specified in "Max. input current" setting
Auxiliary output overload	Aux overload	Active when an excessive load is detected on the auxiliary output
External temperature sensor error	Ext. T sensor error	Active when the external temperature sensor is not connected while it's use is mandatory like in NiMh battery charging.

Alarm	LCD name	Description
Warning over temperature	Warn. over temperature	Active when the internal temperature is high. If the temperature increases more the device may switch OFF.
Error over temperature	Error over temperature	Active when the internal temperature is too high. To prevent damage the device switches OFF.
Output short circuit	Output short circuit	Active when a short circuit is detected on the output.
Internal failure	Internal failure	Active when an internal failure is detected.

6.4.2 DUSH System Events

Event	LCD name	Description
Power ON event	Power ON	Generated at every time the DUSH is turned ON.
Shutdown event	Shutdown	Generated at every time the DUSH is turned OFF. Cause/reason of shutdown: <ul style="list-style-type: none"> • Deep discharge • Max. backup time elapsed • Shutdown command • Reset command • Inhibit signal • Power down
Battery cycle triggered by	Bat. cycle triggered by	“Bat. cycle triggered by Schedule” if the battery cycle is started automatically on scheduled date/time, “Bat. cycle triggered by User” if the battery cycle is started by user.
Battery cycle ended by	Bat. cycle ended by	Specifies the cause/reason of battery cycle ending State of charge: Battery cycle ended at specified state of charge Time limit: Battery cycle ended after specified time Input UV: Battery cycle end caused by the input under voltage Battery in charge: Battery cycle ended because the battery was charging User: Battery cycle stopped by user

6.5 INFO

While in the info menu, use the UP/DOWN KEY to navigate through the menu items. The fields are also accessible via Modbus at the specified address. Modbus device identification fields are read using function 43/13 (0x2B/0x0E) at the specified object id.

Parameter	Description	Value
Firmware version	Shows the Firmware version installed on the DUSH. 3.3 digit indicating the firmware major minor version	001.013
Firmware subversion	Shows the subversion of the installed Firmware on the DUSH. 3 digit indicating the firmware subversion.	001
Build date	Shows the Firmware build date	Jan 01 2024
Build time	Shows the Firmware build time	14:40:05
Serial number	Shows the device serial number	2242.908.03.0001
Boot cycles	Shows the count of power ON cycles.	117 cycles
Operating time	Shows the DUSH operating hour counter.	100 h
Battery operating time	Shows the hours elapsed since the "Battery installation date"	100 h
Next battery cycle	Information about next battery cycle	Date: Date and time of next scheduled battery cycle Cycle disabled: The battery cycle function is disabled In progress: The battery cycle is in progress

6.6 LOGS

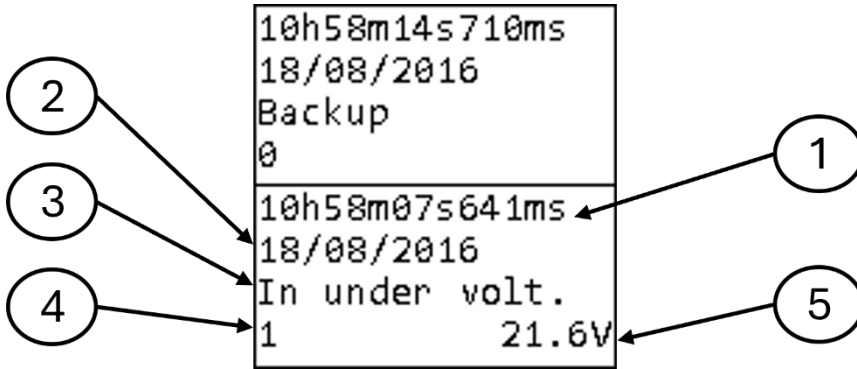

Figure 23 : Menu LOGS

- 1** Time: time at which the log occurred
- 2** Date: date at which the log occurred
- 3** LCD Name: unique log name
- 4** Value1: optional, see tables below for details
- 5** Value2: optional, see tables below for details

Logs are of 3 different kinds: info, alarms and events. All info and alarms have an associated Modbus field representing the current status (0 if inactive or 1 if active). For info and alarms a log is generated at each status transaction. In case of active alarm, the front LED and the buzzer turn ON.

6.6.1.1 Info

LCD Name	Description	Value 1	Value 2
Bat charging	Battery charging: Active when the battery is charging.	0 – inactive 1 – active	Not used
Bat floating	Battery floating: Active when the battery is fully charged.	0 – inactive 1 – active	Not used
Bat discharging	Battery discharging: Active when the battery is discharging.	0 – inactive 1 – active	Not used
Battery cycle active	Battery cycle active: Active when a battery cycle is in progress.	0 – ended 1 – started	Status 0 → 1: Battery voltage at battery cycle start Status 1 → 0: Minimum battery voltage during battery cycle
USB powered	USB powered: DUSH960-1248-xM is powered by USB only.	0 – inactive 1 – active	Not used
Cold start	Cold start: DUSH960-1248-xM has powered ON through cold start.	0 – inactive 1 – active	Not used

LCD Name	Description	Value 1	Value 2
PC shutdown	PC shutdown: Command to shutdowns the PC.	0 – inactive 1 – active	Not used
PC power OFF	PC power off: Command to power OFF the PC, DUSH960-1248-xM output switches OFF.	0 – inactive 1 – active	Not used
Ext. T sensor presence	External temperature sensor presence: Active if the optional external temperature sensor is connected.	0 – inactive 1 – active	Not used
Inhibit	Inhibit: Active if the inhibit input signal is asserted.	0 – inactive 1 – active	Not used
Output disabled	Output disabled: Active if the output is disabled in settings.	0 – inactive 1 – active	Not used
Aux disabled	Auxiliary output disabled: Active if the auxiliary output is disabled in settings.	0 – inactive 1 – active	Not used

6.6.1.2 Alarm

LCD Name	Description	Value 1	Value 2
Bat. disconnected	Battery disconnected: Active when no battery is detected by DUSH960-1248-xM.	0 – inactive 1 – active	Not used
Bat. Ri too high	Battery Ri too high: Active when measured battery internal resistance exceed the alarm threshold (→ 5.1 Battery health monitor).	0 – inactive 1 – active	Status 0 → 1: Offending threshold Status 1 → 0: Max. measured value
Bat. under temperature	Battery under temperature: Active when the battery measured temperature (using the optional external sensor) is under the threshold specified in “Battery min. temperature” field. If active the battery charged is disabled.	0 – inactive 1 – active	Status 0 → 1: Offending threshold Status 1 → 0: Min. measured value
Bat. over temperature	Battery over temperature: Active when the battery	0 – inactive 1 – active	Status 0 → 1: Offending threshold

LCD Name	Description	Value 1	Value 2
	measured temperature (using the optional external sensor) is under the threshold specified in "Battery max. temperature" field. If active the battery charged is disabled.		Status 1 → 0: Max. measured value
Bat. lifetime elapsed	Battery lifetime elapsed: Active when the actual calculated battery lifetime exceeds the threshold specified in "Battery lifetime" field	0 – inactive 1 – active	Status 0 → 1: Offending threshold Status 1 → 0: Max. calculated value
Bat. charge fail	Battery charge failure: Active when DUSH960-1248-xM could not charge the battery correctly. When active, the battery charger is disabled. Disconnect the battery to reset the alarm.	0 – inactive 1 – active	Not used
Bat. SoC < 25%	Battery SoC < 25%: Active when the battery State of Charge is under 25 % of the nominal full charge capacity.	0 – inactive 1 – active	Not used
Bat. over discharge I	Battery over discharge current: Active when the measured battery discharge current reaches the threshold specified in "Battery max. discharge current" field.	0 – inactive 1 – active	Status 0 → 1: Offending threshold Status 1 → 0: Max. measured value
Bat. low	Battery low: Active when the measured battery voltage is under the threshold specified in "Battery low voltage" field.	0 – inactive 1 – active	Status 0 → 1: Offending threshold Status 1 → 0: Min. measured value
Bat. deep discharge	Battery deep discharged: Active when the battery measured voltage is under the threshold specified in "Battery deep discharge voltage" field.	0 – inactive 1 – active	Status 0 → 1: Offending threshold Status 1 → 0: Min. measured value
Backup	Backup: Active when the system is in backup.	0 – inactive 1 – active	Not used

LCD Name	Description	Value 1	Value 2
Input under voltage	Input under voltage: Active when the measured input voltage is under 90 % of the "Nominal output voltage" field.	0 – inactive 1 – active	Status 0 → 1: Offending threshold Status 1 → 0: Min. measured value
Input over voltage	Input over voltage: Active when the measured input voltage exceeds 120 % of the "Nominal output voltage" field.	0 – inactive 1 – active	Status 0 → 1: Offending threshold Status 1 → 0: Max. measured value
Output under voltage	Output under voltage: Active when the measured output voltage is under 90 % of the "Nominal output voltage" field.	0 – inactive 1 – active	Status 0 → 1: Offending threshold Status 1 → 0: Min. measured value
Output over voltage	Output over voltage: Active when the measured output current reaches the threshold specified in "Max. output current" field.	0 – inactive 1 – active	Not used
Output overload	Output overload: Active when the measured output current reaches the threshold specified in "Max. output current" field	0 – inactive 1 – active	Not used
Input over current	Input over current: Active when the measured input current reaches the threshold specified in "Max. input current" field.	0 – inactive 1 – active	Not used
Aux overload	Auxiliary output overload: Active when an excessive load is detected on the auxiliary output.	0 – inactive 1 – active	Not used
Ext. T sensor error	External temperature sensor error: Active when the external temperature sensor is not connected while it's use is mandatory like in NiMh battery charging.	0 – inactive 1 – active	Not used
Backup time left < 25%	Backup time left < 25 %: Active when the system	0 – inactive 1 – active	Not used

LCD Name	Description	Value 1	Value 2
	is in backup and the maximal backup time is less than the "Max. backup time" filed		
Warn. over temperature	Warning over temperature: Active when the internal temperature is high. If the temperature increases more the device may switch OFF.	0 – inactive 1 – active	Not used
Error over temperature	Error over temperature: Active when the internal temperature is too high. To prevent damage the device switches OFF.	0 – inactive 1 – active	Not used
Output short circuit	Output short circuit: Active when a short circuit is detected on the output.	0 – inactive 1 – active	Not used
Internal failure	Internal failure: Active when an internal failure is detected.	0 – inactive 1 – active	Internal fail code

6.6.1.3 Event

LCD Name	Description	Value 1	Value 2
Power ON	Power ON event: Generated at every time the DUSH960-1248-xM is turned ON.	Power ON count	Not used
Shutdown	Shutdown event: Generated at every time the DUSH960-1248-xM is turned OFF.	Shutdown count	Shutdown reason: 1 – Deep discharge 2 – Max. backup time elapsed 3 – Shutdown command 4 – Reset command 5 – Inhibit signal 6 – Power down
Bat. cycle triggered by	Battery cycle triggered by; Schedule (0) if the battery cycle is started automatically on scheduled date/time, User (1) if the battery cycle is started by user.	0 – Schedule 1 – User	Not used
Bat. cycle ended by	Battery cycle ended by: Specifies the	1 – State of charge 2 – Time limit	Not used

LCD Name	Description	Value 1	Value 2
	cause/reason of battery cycle ending	3 – Input UV 4 – Battery in charge 5 – User	
	<ul style="list-style-type: none"> • State of charge: Battery cycle ended at specified state of charge • Time limit: Battery cycle ended after specified time • Input UV: Battery cycle end caused by the input under voltage • Battery in charge: Battery cycle ended because the battery was charging • User: Battery cycle stopped by user 		

6.7 Configuration Wizard

The wizard assists the user to configure the system through a series of screens during the DUSH configuration. It can be run at commissioning. The user should follow the screens.

6.8 ON/OFF function

An opto-isolated input allows the inhibition of the backup function in UPS mode or switching off the output on DC/DC mode. The polarity of the input can be defined using the “Inhibit polarity” setting.

7 Communication interfaces

7.1 Modbus RTU

With a MODBUS/RTU interface as standard the DUSH960-1248-xM can be easily connected directly to the control level in intelligent industrial environments. Over 50 real-time status values for monitoring, enabling the early identification of status changes or even failures. Numerous adjustable parameters make complete remote maintenance of the system possible.

Specific setting information and complete Modbus address information are available in the separate Modbus Application note at <https://www.emea.lambda.tdk.com/dush-series>.

NOTICE

DUSH960-1248-xM communicates through Modbus/RTU as specified on [MODBUS over Serial Line](#) and [MODBUS APPLICATION PROTOCOL SPECIFICATION](#). Documents available on <http://www.modbus.org/>.

7.2 Remote HMI

The TDK-Lambda control and monitoring center "PowerCMC" offers a comfortable remote maintenance and control of the DUSH DIN-Rail UPS system.

All values and parameters can be set and/or adjusted. Comprehensive save and recall options of the system settings and parameters make the maintenance workflow easy.

The PowerCMC is available for download on our product website:
<https://www.emea.lambda.tdk.com/dush-series>.

8 Operating and basic functions

8.1 System overview

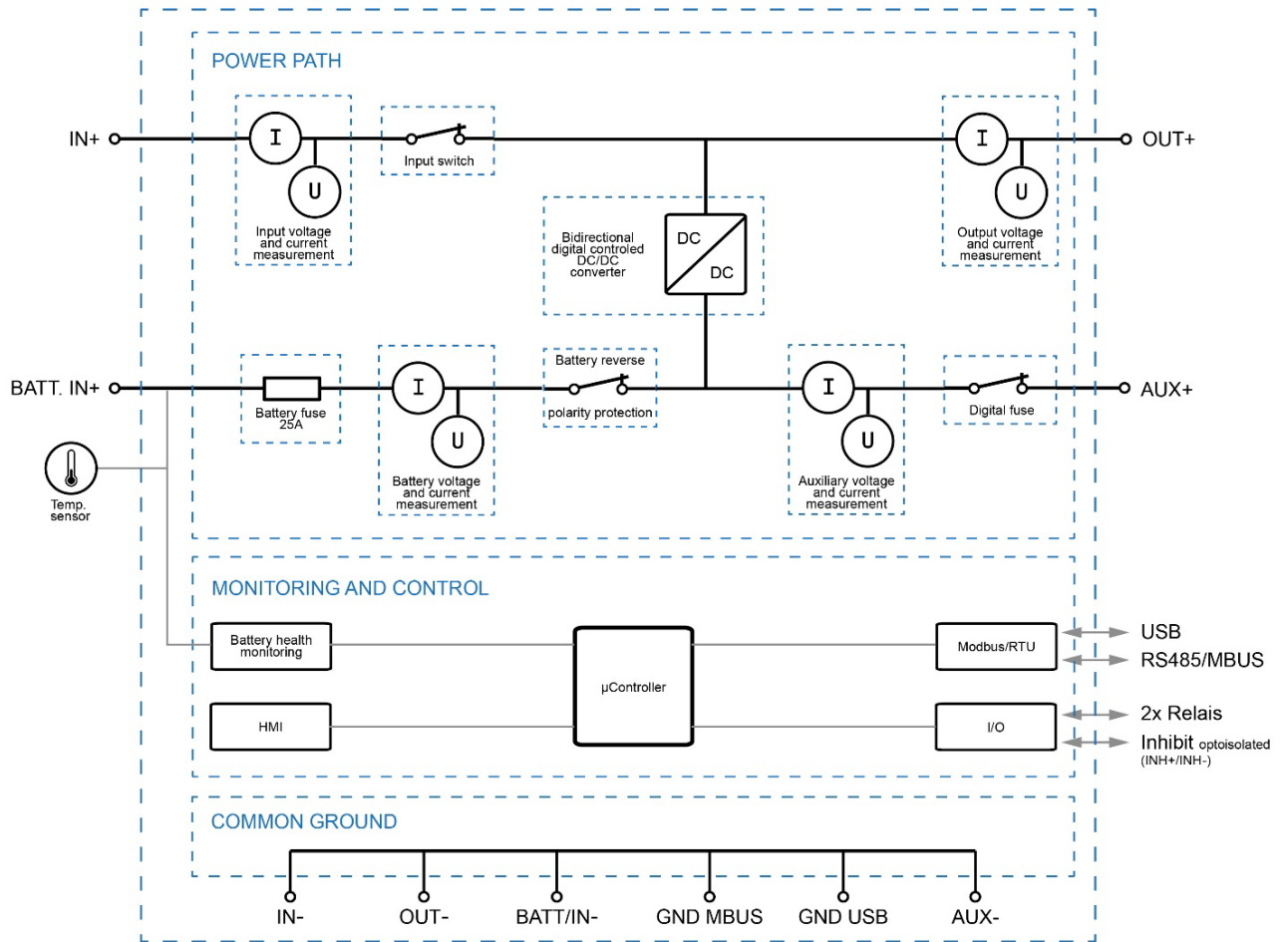

Figure 24 : System overview

8.2 Input-Output path

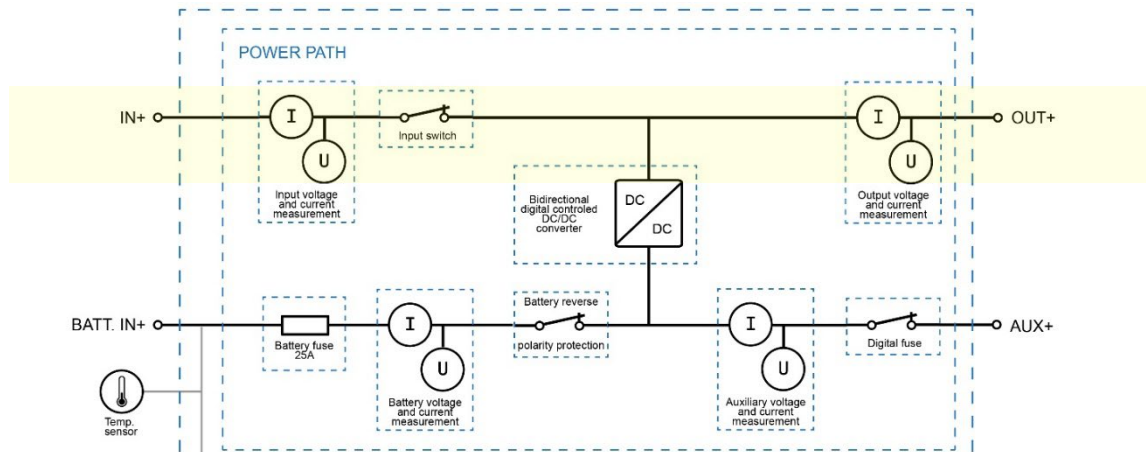

Figure 25 : Input-Output path

The Input to Output path of the DUSH is not regulated and has a nominal range of $12V_{DC} \dots 48V_{DC}$ (max. $10V_{DC} \dots 60V_{DC}$). There is no protection on the Input – Output path hence a fitting power supply must be used at the input of the DUSH. An appropriate fuse for the input protection must be installed at the input of the DUSH. The power supply on the input of the DUSH must also correspond to the maximum performance data of the DUSH to avoid damaging the input/output path. The short-circuit behavior of the power supply at the input must also be considered to avoid any damage of the load. A constant measurement of the voltage and current on the input and output is used for the internal monitoring and alarm functions.

8.3 Battery-Output path

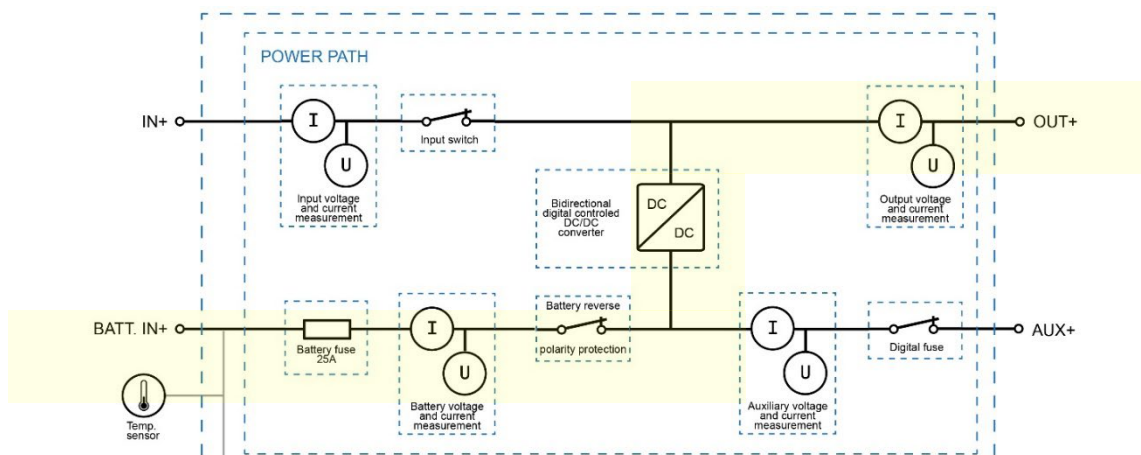

Figure 26 : Battery-Output path

The Battery to Output path of the DUSH is regulated by a bidirectional DC/DC - buck/boost converter. Due to the buck/boost converter the installed battery voltage and the set output voltage can differ. It is therefore possible that the installed battery voltage differs from the output voltage. If a lower battery voltage is used the output power will be reduced accordingly due to the lower battery voltage. The Battery to Output path contains a internal 25A fuse for the battery input protection as well as a battery reverse polarity protection to avoid any damage in case of a reverse connected battery on the DUSH. The internal battery fuse is not user replaceable. A constant measurement of the voltage and current on the battery input and the output is used for the battery health monitoring as well as the charge and discharge regulation. It is also used for monitoring and alarm functions. An additional measurement of the internal resistance of the battery incl. the battery wiring supports the battery health monitoring.

8.4 Auxiliary output

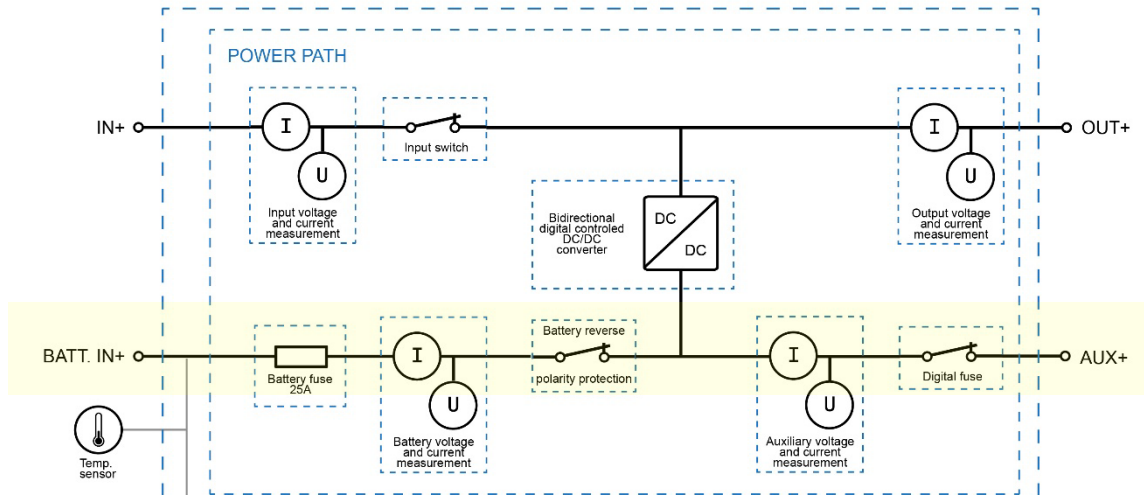

Figure 27 : Auxiliary output

The auxiliary output of the DUSH is powered from the battery with no regulation. The auxiliary voltage follows the battery voltage in a range of $12V_{DC} \dots 48V_{DC}$ with a maximum current of 5A.

A digital fuse protects the auxiliary output. A constant measurement of the voltage and current on the is used for the internal monitoring and alarm functions.

8.5 Typical wiring diagram

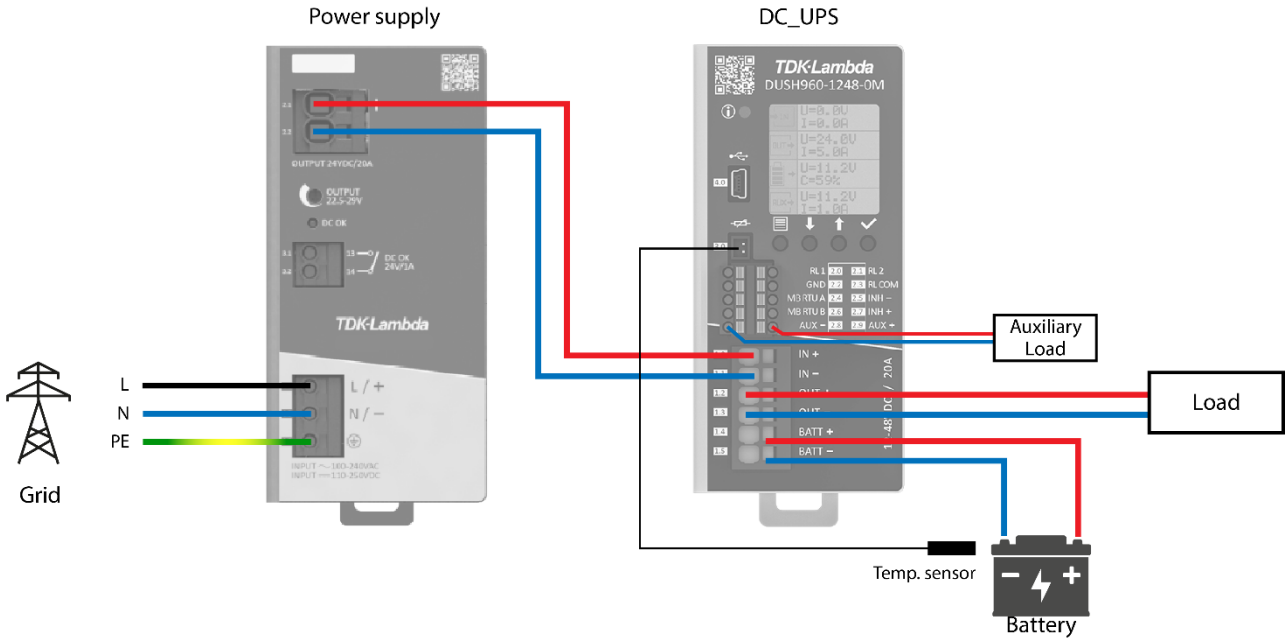

Figure 28 : Power connection

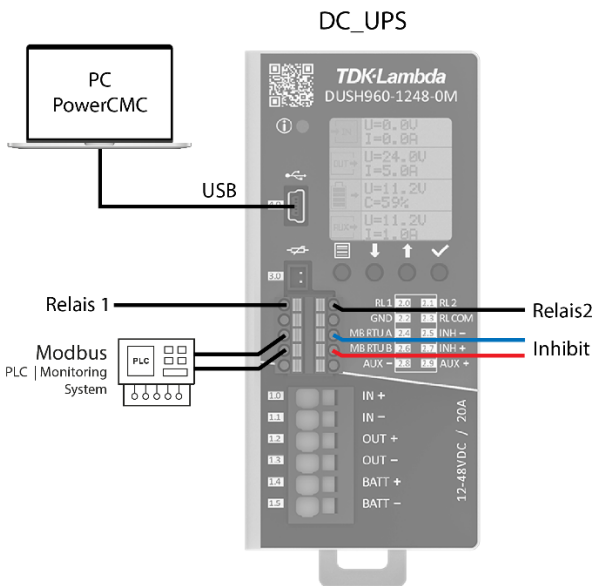

Figure 29 : I/O connection

9 Energy storage technologies

9.1 Buffer technologies

9.1.1 Lead acid / Lead gel

9.1.1.1 Advantages

- Maintenance free; low self-discharge
- Performance stays high until the end of life, then drops rapidly
- Dependable and inexpensive on a cost-per-watt base

9.1.1.2 Limitations

- Deep discharge will damage the battery over time
- Relatively short cycle life of 200 ... 300 cycles
- Must be stored in charged condition

9.1.2 Nickel metal hydride

9.1.2.1 Advantages

- Rugged, high cycle count, NiMH has 30 ... 40% higher capacity than NiCd
- Can be ultra-fast charged with little stress
- Long shelf life; can be stored in a discharged state

9.1.2.2 Limitations

- Memory effect; needs periodic full discharges, high self-discharge
- Low cell voltage of 1.20 V requires many cells to achieve high voltage
- Requires complex charge algorithm

9.1.3 Lithium-Ion / Lithium iron phosphate etc.

9.1.3.1 Advantages

- High specific energy and high load capabilities, Low self-discharge
- Long cycle and extend shelf-life; maintenance-free
- High capacity, low internal resistance, good coulombic efficiency

9.1.3.2 Limitations

- Requires protection circuit to prevent thermal runaway
- Transportation regulations required
- Internal BMS can be critical in UPS usage

9.1.4 Supercapacitors

9.1.4.1 Advantages

- Virtually unlimited cycle life
- High specific power; low resistance enables high load currents
- Charges in seconds; no end-of-charge termination required

9.1.4.2 Limitations

- Low specific energy; holds a fraction of a regular battery
- High self-discharge; higher than most batteries
- High cost per watt

9.2 Series and parallel connection of batteries

Series connection

to increase the battery voltage

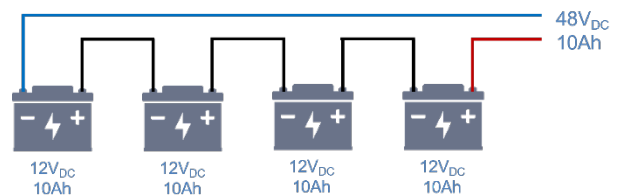

Parallel connection

to increase the capacity

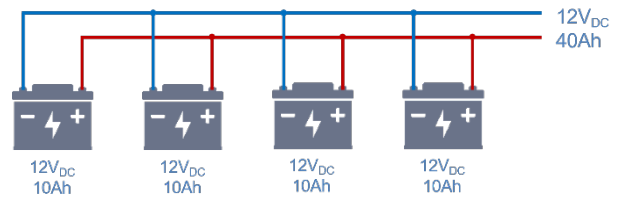

Series & parallel connection

combined to increase the battery voltage and the capacity

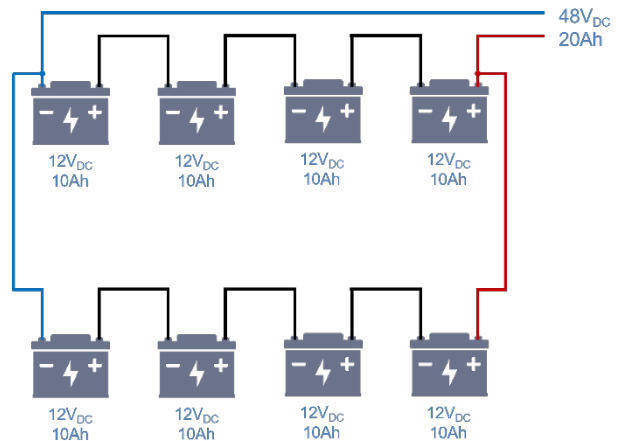

9.3 Deep discharge

To ensure the service life and safety of the battery, deep discharges should be avoided. A deep discharge occurs when the voltage falls below a certain value. The deep discharge voltage is specified by the battery manufacturer.

The consequences of a deep discharge can permanently damage the battery depending on the battery type and usage. Here are some general effects:

- Loss of capacity: the battery can store less energy.
- Shortening of the service life
- Damage to the cells: Especially with lithium-ion batteries, the cells can be irreparably damaged.
- Increased self-discharge: The battery can lose charge more quickly, even when not in use.
- Safety risks: In extreme cases, overheating or even fires can occur, especially with lithium-ion batteries.

To protect a battery from deep discharge, there are the following measures:

- Charge regularly: To keep the voltage above the critical value, the battery should be charged regularly.
- Monitoring the voltage: To check the battery voltage regularly, use the monitoring functions of the DUSH960-1248-xM.
- Avoid complete discharge: For lithium-ion batteries, it is recommended to keep the charge between 20 % ... 80 %.
- Storage at the correct temperature: Extreme cold or heat can accelerate self-discharge and damage the battery.

9.4 Recommended battery models

The DUSH DC-UPS works with batteries and super capacitors up to a capacity of 1000Ah. The supported battery types are Lead, Nickel and Lithium.

9.5 Discharge tables and diagrams

The diagram shows typical discharge curves in relation to the output current of the DC UPS. The original values of the battery manufacturer must be considered depending on the respective application. The values shown here are for guidance only.

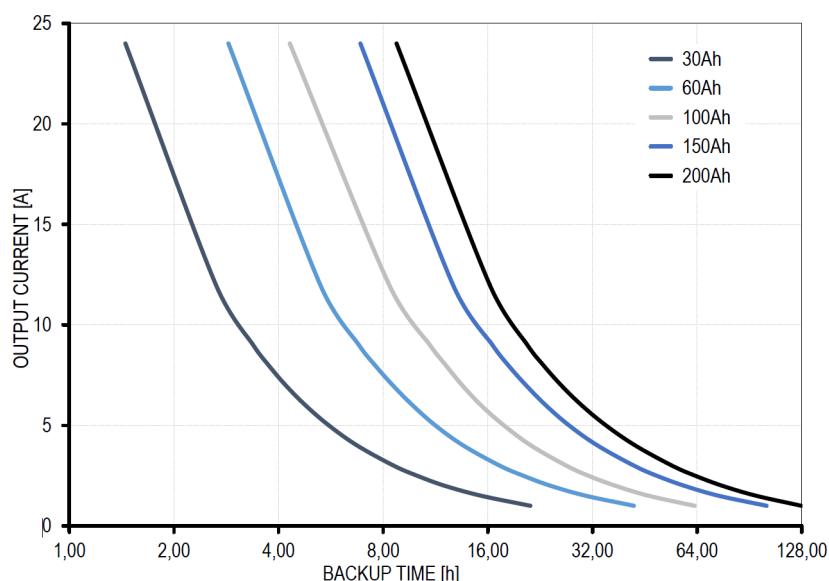

Figure 30 : Battery discharge curves (typical)

9.6 Battery temperature compensation

The chemistry in lead-acid batteries causes energy to flow more easily in warm temperatures and less easily in cold temperatures. This affects how much energy a battery can absorb during the recharge process. Most charger voltage setpoints are set for room temperature 25°C (77°F). If that setpoint is not adjusted for temperature, the battery might get overcharged and gas when it's too warm, or undercharge and sulfate when it's too cold. The result of either scenario is a battery with a shortened lifespan, sometimes significantly if exposed to extreme conditions.

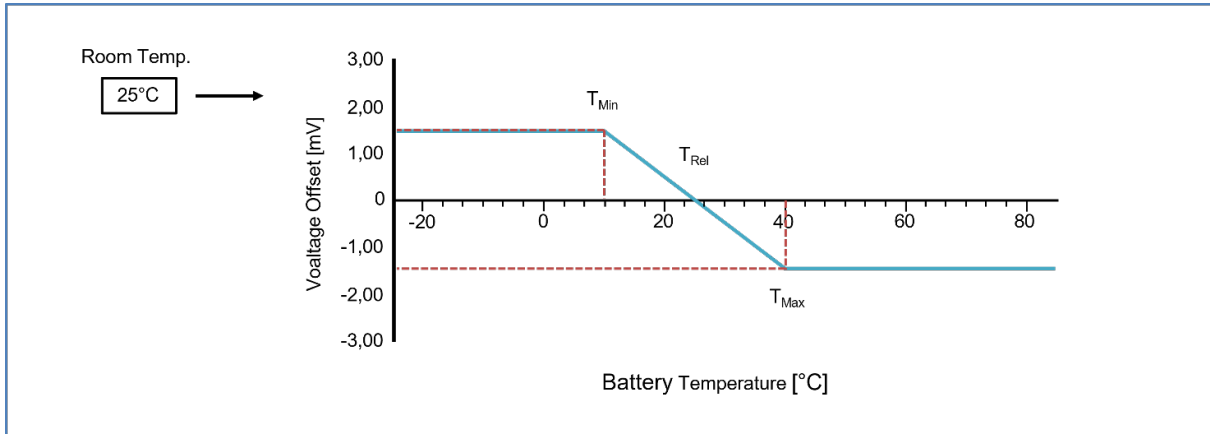

Figure 31 : Temperature compensation

To compensate for this, the DUSH series can be used with an external temperature sensor to operate the temperature compensation algorithm. The temperature sensor is available in two models.

- ACC-DUSH-DTX01-0X – 10kOhm NTC sensor with plug connector, cable length 1m
- ACC-DUSH-DTX02-0X – 10kOhm NTC sensor with plug connector, cable length 2m

10 Technical data

ⓘ NOTICE

The complete technical data can be found in the technical specification

→ <https://www.emea.lambda.tdk.com/dush-series>.

TDK-Lambda



TDK-Lambda France SAS
Tel: +33 1 60 12 71 65
tff.fr-powersolutions@tdk.com
www.emea.lambda.tdk.com/fr



Italy Sales Office
Tel: +39 02 61 29 38 63
tff.it-powersolutions@tdk.com
www.emea.lambda.tdk.com/it



Netherlands
tff.nl-powersolutions@tdk.com
www.emea.lambda.tdk.com/nl



TDK-Lambda Germany GmbH
Tel: +49 7841 666 0
tfg.powersolutions@tdk.com
www.emea.lambda.tdk.com/de



Austria Sales Office
Tel: +43 2256 655 84
tfg.at-powersolutions@tdk.com
www.emea.lambda.tdk.com/at



Switzerland Sales Office
Tel: +41 44 850 53 53
tfg.ch-powersolutions@tdk.com
www.emea.lambda.tdk.com/ch



Nordic Sales Office
Tel: +45 8853 8086
tfg.dk-powersolutions@tdk.com
www.emea.lambda.tdk.com/dk



TDK-Lambda UK Ltd.
Tel: +44 (0) 12 71 85 66 66
tfu.powersolutions@tdk.com
www.emea.lambda.tdk.com/uk



TDK-Lambda Ltd.
Tel: +9 723 902 4333
tvi.powersolutions@tdk.com
www.emea.lambda.tdk.com/il-en



TDK-Lambda Americas
Tel: +1 800-LAMBDA-4 or 1-800-526-2324
tla.powersolutions@tdk.com
www.us.lambda.tdk.com



TDK Electronica do Brasil Ltda
Tel: +55 11 3289-9599
sales.br@tdk-electronics.tdk.com
www.tdk-electronics.tdk.com/en



TDK-Lambda Corporation
Tel: +81-3-6778-1113
www.jp.lambda.tdk.com



TDK-Lambda (China) Electronics Co. Ltd.
Tel: +86 21 6485-0777
tfc.powersolutions@tdk.com
www.lambda.tdk.com.cn



TDK-Lambda Singapore Pte Ltd.
Tel: +65 6251 7211
tts.marketing@tdk.com
www.sg.lambda.tdk.com



TDK India Private Limited, Power Supply Division
Tel: +91 80 4039-0660
mathew.philip@tdk.com
www.sg.lambda.tdk.com