

EZCast Pro Dongle II

Model: D10



Specification

V1.04

General Description:

EZCast Pro Dongle II is the most powerful WiFi display dongle product fitting in a small form factor. With broad OS platforms support, it can empower your mobile device and cast small displays to a bigger one.

It builds in 802.11ac dual antenna (2T2R) so that you can have best WiFi performance and anti-interfering capability. With the powerful EZCast Pro app, you now can do split screens display while you're in a meeting, and you can also use the new AirView and EZNote feature to share content or make notes. We also release a powerful screen broadcast app "ProCast", so that you can cast your content to multiple EZCast Pro Dongle 2 simultaneously, it will definitely be the best solution for small offices and classrooms.

System Requirements

HW environment:

- TV, Monitor or Projector with HDMI 1.4a input
- DC 5V/1.5A, with type-c USB connector

SW environment for app:

- iOS: 10 and above
- Android: Android 5.0 and above
- MacOS: macOS 10.12 and after
- Windows: Windows 7 and above
- ChromeOS

**specifications are subject to change without notice due to different OS platform regulations.*

Hardware Specification

CPU	AM8270
DRAM	DDR3 1GB
Flash	NAND Flash 256MB
Output Resolution	<ul style="list-style-type: none"> ● 4096x2160@24hz ● 3840x2160@30hz ● 3840x2160@25hz ● 3840x2160@24hz ● 1920x1080@60Hz ● 1280x720@60hz ● 1280x720@50hz ● 1920x1080@50Hz ● 1920x1080@24Hz
I/O	<ul style="list-style-type: none"> ● HDMI out (HDMI1.4) ● USB type-C connector for DC 5V
WiFi	<ul style="list-style-type: none"> ● 802.11ac 2T2R, max. bandwidth 866Mbps (@5Ghz)
WiFi Frequency	5Ghz: 5.150Ghz~5.825Ghz (may vary in different countries)
Power	DC 5V, 1.5A
Video Support	<p>Capable of decoding 1080@60 video with most formats</p> <ul style="list-style-type: none"> ● H.265 MP@L5.0 High Tier ● Supports HD MPEG4 SP/ASP (720p/1080i/1080p) ● H.264 BP@L3, MP and HP@L4.2 ● H.264 MVC SHP@L4.1 ● VC-1 SP, MP, AP@L3 ● AVS JZ@L6.2, AVS+ 1080@60P ● VP8 1080@60P ● Video up-scaling from SD to Ultra HD (720p/1080i/1080p/2160p)
DRM and Link Protection	HDCP2.2 for Miracast

LED Indication	Power, WiFi status
Key	Reset button
Power Consumption	<ul style="list-style-type: none"> ● Standby: 2W approx. ● Casting: 5W approx.
Working Temp.	0~40°C
Storage Temp.	-20~70°C

Operation mode

- Screen Cast:
 - EZCast Pro App to support screen cast, note taking, split screen to one receiver.
 - 3-in-1 mode under main page: Airplay/DLNA/Miracast
- Screen Broadcast:
 - 1 pc to 8 receivers (depends on WiFi bandwidth) screen broadcast under local network.
- WiFi: Direct Link(SoftAP) / Infrastructure(Client) / WiFi Direct(Miracast concurrently)

Mechanical Design&Dimension

- L 87.5mm x W 32mm x H 12mm (L99mm if includes HDMI connector)

Weight

- Body: 100g approx. (not including accessory)
- Complete package: 250g approx..

Accessories

- Short HDMI extension cable x1
- Type-C USB cable x1
- QSG x1

SW Features:

Operation Mode	Link and Offline operation
Control Mode	Admin, Host and Guest
Screen Mirror	<ul style="list-style-type: none">● EZCast Pro App for Win/Mac: Mirror/Extension mode● Airplay: Mirror, Extension(macOS only)● Miracast for Windows and Android: Mirror, Extension(windows only)
Multimedia Cast	Photo/Video cast
Office Viewer	MS-Office and PDF
Editing Tool	Sketch tool

Web Browser	Embedded browser
Cloud Video	EZChannel for video entrance
Content Broadcast	Airview to broadcast current display
Camera	Live camera to support front and rear camera
Split Screen	1, 2, or 4 displays
Advanced	<ul style="list-style-type: none"> -Administrator login -WPA enterprise CA -Conference control for users and display positions -Link status check -AirView on/off switch -AirSetup -Reset to default
EZNote	Note taking and editor
EZKeep	EZNote to be stored on Cloud
EZBoard	Cross platform interactive board
Privacy	Preferred device setting, Do not disturb mode and auto-allow settings
Others	Comments and Store
ProCast (Multiple device broadcast)	Single PC to multiple devices screen mirror (Windows and macOS only)

*Above features are subject to change without notice due to different OS platform regulations.

EZCast Pro Dongle 2

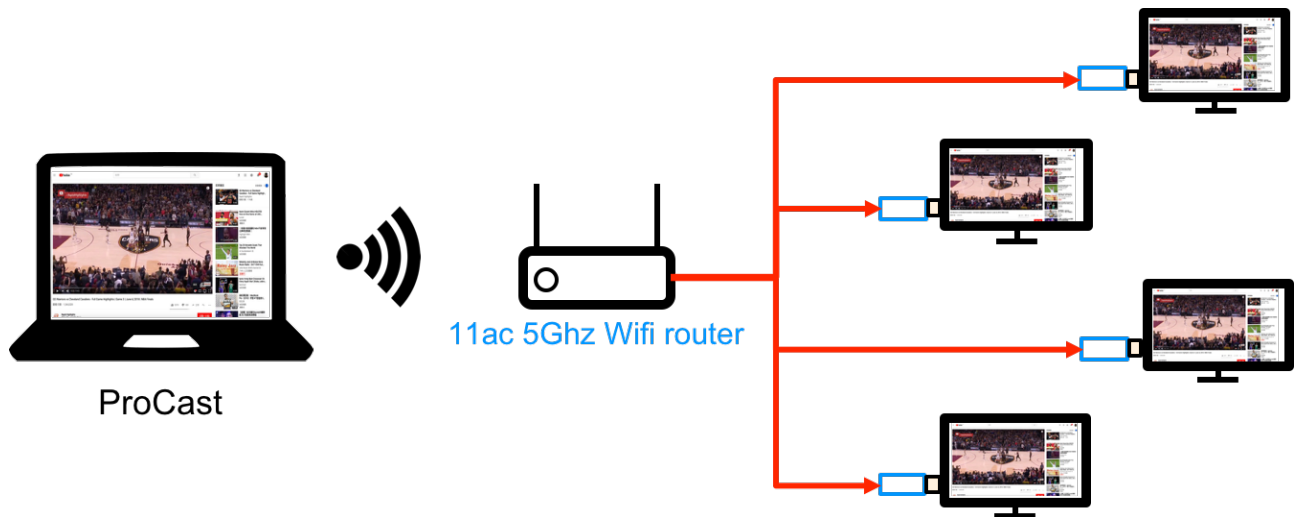
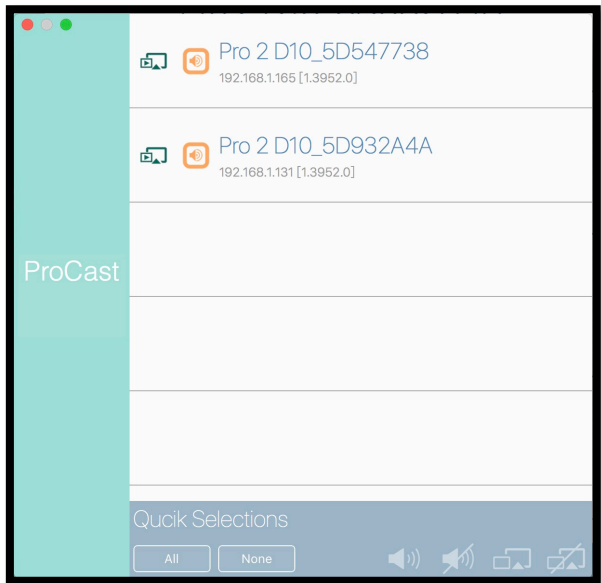
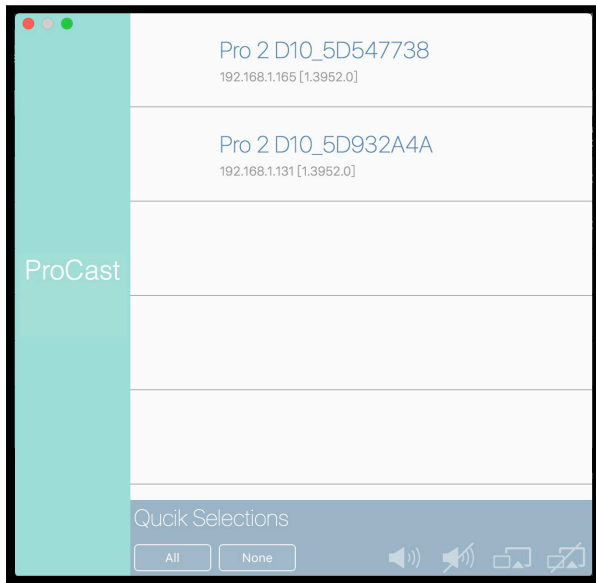

WiFi Channel Table (5Ghz, 20Mhz):

Band range	Operating Channel Numbers	Channel center frequencies(MHz)
5180 MHz~5240MHz	36	5180
	40	5200
	44	5220
	48	5240
5260MHz~5320MHz	52	5260
	56	5280
	60	5300
	64	5320
5550MHz~5700MHz	100	5500
	104	5520
	108	5540
	112	5560
	116	5580
	120	5600
	124	5620
	128	5640
	132	5660
	136	5680
5745MHz~5825MHz	140	5700
	149	5745
	153	5765
	157	5785
	161	5805
	165	5825

WiFi RF Parameters (5Ghz):

Feature	Description
WLAN Standard	IEEE 802.11ac 2x2, WiFi compliant
Frequency Range	4.900 GHz ~ 5.845 GHz (5.0 GHz ISM Band)
Number of Channels	5.0GHz : Please see the table ¹
Output Power	802.11a /54Mbps : 13 dBm \pm 1.5 dB @ EVM \leq -25dB
	802.11n /MCS7 : 12 dBm \pm 1.5 dB @ EVM \leq -28dB
	802.11ac /MCS9 : 10 dBm \pm 1.5 dB @ EVM \leq -32dB
SISO Receive Sensitivity (11a,20MHz) @10% PER	- 6Mbps PER @ -88 dBm, typical
	- 9Mbps PER @ -87 dBm, typical
	- 12Mbps PER @ -86 dBm, typical
	- 18Mbps PER @ -83 dBm, typical
	- 24Mbps PER @ -80 dBm, typical
	- 36Mbps PER @ -77 dBm, typical
	- 48Mbps PER @ -72 dBm, typical
	- 54Mbps PER @ -70 dBm, typical
MIMO Receive Sensitivity (11a,20MHz) @10% PER	- 6Mbps PER @ -90 dBm, typical
	- 9Mbps PER @ -89 dBm, typical
	- 12Mbps PER @ -88 dBm, typical
	- 18Mbps PER @ -86 dBm, typical
	- 24Mbps PER @ -83 dBm, typical
	- 36Mbps PER @ -80 dBm, typical
	- 48Mbps PER @ -75 dBm, typical
	- 54Mbps PER @ -71 dBm, typical
SISO Receive Sensitivity (11n,20MHz) @10% PER	- MCS=0 PER @ -88 dBm, typical
	- MCS=1 PER @ -85 dBm, typical
	- MCS=2 PER @ -83 dBm, typical
	- MCS=3 PER @ -80 dBm, typical
	- MCS=4 PER @ -76 dBm, typical
	- MCS=5 PER @ -71 dBm, typical
	- MCS=6 PER @ -70 dBm, typical
	- MCS=7 PER @ -68 dBm, typical
MIMO Receive Sensitivity (11n,20MHz) @10% PER	- MCS=0 PER @ -89 dBm, typical
	- MCS=1 PER @ -88 dBm, typical
	- MCS=2 PER @ -86 dBm, typical
	- MCS=3 PER @ -83 dBm, typical

	- MCS=4 PER @ -79 dBm, typical
	- MCS=5 PER @ -74 dBm, typical
	- MCS=6 PER @ -73 dBm, typical
	- MCS=7 PER @ -71 dBm, typical
	- MCS=8 PER @ -88 dBm, typical
	- MCS=15 PER @ -68 dBm, typical
SISO Receive Sensitivity (11n,40MHz) @10% PER	- MCS=0 PER @ -85 dBm, typical
	- MCS=1 PER @ -82 dBm, typical
	- MCS=2 PER @ -80 dBm, typical
	- MCS=3 PER @ -77 dBm, typical
	- MCS=4 PER @ -73 dBm, typical
	- MCS=5 PER @ -69 dBm, typical
	- MCS=6 PER @ -67 dBm, typical
MIMO Receive Sensitivity (11n,40MHz) @10% PER	- MCS=7 PER @ -66 dBm, typical
	- MCS=0 PER @ -87 dBm, typical
	- MCS=1 PER @ -85 dBm, typical
	- MCS=2 PER @ -83 dBm, typical
	- MCS=3 PER @ -80 dBm, typical
	- MCS=4 PER @ -76 dBm, typical
	- MCS=5 PER @ -72 dBm, typical
	- MCS=6 PER @ -70 dBm, typical
	- MCS=7 PER @ -69 dBm, typical
- MCS=8 PER @ -85 dBm, typical	
SISO Receive Sensitivity (11ac,20MHz) @10% PER	- MCS=15 PER @ -66 dBm, typical
	- MCS=0, NSS1 PER @ -86 dBm, typical
	- MCS=1, NSS1 PER @ -84 dBm, typical
	- MCS=2, NSS1 PER @ -82 dBm, typical
	- MCS=3, NSS1 PER @ -79 dBm, typical
	- MCS=4, NSS1 PER @ -75 dBm, typical
	- MCS=5, NSS1 PER @ -70 dBm, typical
	- MCS=6, NSS1 PER @ -69 dBm, typical
	- MCS=7, NSS1 PER @ -68 dBm, typical
- MCS=8, NSS1 PER @ -64 dBm, typical	
MIMO Receive Sensitivity (11ac,20MHz) @10% PER	- MCS=0, NSS1 PER @ -88 dBm, typical
	- MCS=1, NSS1 PER @ -87 dBm, typical
	- MCS=2, NSS1 PER @ -85 dBm, typical
	- MCS=3, NSS1 PER @ -82 dBm, typical
	- MCS=4, NSS1 PER @ -78 dBm, typical

	- MCS=5, NSS1 PER @ -73 dBm, typical
	- MCS=6, NSS1 PER @ -72 dBm, typical
	- MCS=7, NSS1 PER @ -71 dBm, typical
	- MCS=8, NSS1 PER @ -67 dBm, typical
	- MCS=0, NSS2 PER @ -87 dBm, typical
	- MCS=8, NSS2 PER @ -63 dBm, typical
SISO Receive Sensitivity (11ac,40MHz) @10% PER	- MCS=0, NSS1 PER @ -84 dBm, typical
	- MCS=1, NSS1 PER @ -81 dBm, typical
	- MCS=2, NSS1 PER @ -79 dBm, typical
	- MCS=3, NSS1 PER @ -76 dBm, typical
	- MCS=4, NSS1 PER @ -73 dBm, typical
	- MCS=5, NSS1 PER @ -68 dBm, typical
	- MCS=6, NSS1 PER @ -67 dBm, typical
	- MCS=7, NSS1 PER @ -66 dBm, typical
	- MCS=8, NSS1 PER @ -61 dBm, typical
	- MCS=9, NSS1 PER @ -60 dBm, typical
MIMO Receive Sensitivity (11ac,40MHz) @10% PER	- MCS=0, NSS1 PER @ -86 dBm, typical
	- MCS=1, NSS1 PER @ -84 dBm, typical
	- MCS=2, NSS1 PER @ -82 dBm, typical
	- MCS=3, NSS1 PER @ -79 dBm, typical
	- MCS=4, NSS1 PER @ -76 dBm, typical
	- MCS=5, NSS1 PER @ -71 dBm, typical
	- MCS=6, NSS1 PER @ -70 dBm, typical
	- MCS=7, NSS1 PER @ -69 dBm, typical
	- MCS=8, NSS1 PER @ -64 dBm, typical
	- MCS=9, NSS1 PER @ -63 dBm, typical
	- MCS=0, NSS2 PER @ -84 dBm, typical
	- MCS=9, NSS2 PER @ -60 dBm, typical
SISO Receive Sensitivity (11ac,80MHz) @10% PER	- MCS=0, NSS1 PER @ -81 dBm, typical
	- MCS=1, NSS1 PER @ -78 dBm, typical
	- MCS=2, NSS1 PER @ -76 dBm, typical
	- MCS=3, NSS1 PER @ -72 dBm, typical
	- MCS=4, NSS1 PER @ -69 dBm, typical
	- MCS=5, NSS1 PER @ -66 dBm, typical
	- MCS=6, NSS1 PER @ -64 dBm, typical
	- MCS=7, NSS1 PER @ -62 dBm, typical
	- MCS=8, NSS1 PER @ -58 dBm, typical
	- MCS=9, NSS1 PER @ -56 dBm, typical

MIMO Receive Sensitivity (11ac,80MHz) @10% PER	- MCS=0, NSS1 PER @ -82 dBm, typical
	- MCS=1, NSS1 PER @ -81 dBm, typical
	- MCS=2, NSS1 PER @ -79 dBm, typical
	- MCS=3, NSS1 PER @ -75 dBm, typical
	- MCS=4, NSS1 PER @ -72 dBm, typical
	- MCS=5, NSS1 PER @ -69 dBm, typical
	- MCS=6, NSS1 PER @ -67 dBm, typical
	- MCS=7, NSS1 PER @ -65 dBm, typical
	- MCS=8, NSS1 PER @ -61 dBm, typical
	- MCS=9, NSS1 PER @ -60 dBm, typical
	- MCS=0, NSS2 PER @ -80 dBm, typical
	- MCS=9, NSS2 PER @ -56 dBm, typical
Maximum Input Level	802.11a/n : -30 dBm
Antenna Reference	Small antennas with 0~2 dBi peak gain